

FUEL PUMPS

Purpose and Function

Modern EFI fuel systems circulate as much as 200 litres per hour (~ 3 litres / min) of fuel at pressures between 2.5 - 3.5 bar (250 - 350 kpa)

Modern electric fuel pumps are "Positive Displacement" type pumps, this means that the pump cannot produce pressure unless it is acting upon a restriction. The only restriction in the system should be the fuel pressure regulator. The regulator controls the system pressure; *the pressure **ability** or flow volume capacity of the fuel pump will not alter the system pressure.*

Due to the high pressure and volume requirements placed upon these pumps, manufacturing tolerances are extremely fine. Motor speeds can be as high as 10,000 RPM and the clearances within the pumping elements down to microns. Cleanliness of the fuel system is vital, with an efficient high quality filter as an essential part of the fuel system.

Important Note.

- Bosch Fuel Pumps have their flow rates defined in N-Heptane as part of their engineering specification. N-Heptane is a pure chemical and does not have the same viscosity and density as standard petrol. Hence the N-Heptane flow rate figures stated should be used as a general guide for comparison purposes only.
- Bosch Fuel Pumps are designed for use with standard grade petrol. Subject to statutory warranties, Bosch does not warrant the performance characteristics or specifications of these fuel pumps if they are used with Alcohol or Ethanol based fuels or fuel additives that are corrosive.

FUEL PUMP TECHNICAL DATA

Part Number	Flow Qty* litres / hour (pressure)	Inlet Connection	Outlet Connection	Length (mm)	Diameter (mm)	Max Power Cons (Amps)	Electrical Connection (- / +)
0 580 254 023	168 (5 Bar)	open base	M10 x 1.0	169	60	10	M5/M6
0 580 254 040	102 (6.5 Bar)	open base	M10 x 1.0	169	60	11	M5/M6
0 580 254 044	200 (5 Bar)	M18 x1.5	M12 x 1.5	196	60	15.5	M5/M6
0 580 254 046	207 (3 Bar)	M14 x 1.5	M12 x 1.5 (F)	169	60	10.5	M4/M5
0 580 254 053	175 (5 Bar)	12mm (3/8")	M12 x 1.5	180	60	11.5	M4/M5
0 580 254 909	148 (5 Bar)	12mm (3/8")	M12 x 1.5	180	60	10	M4/M5
0 580 254 910	130 (5 Bar)	15mm (1/2")	M12 x 1.5	203	60	10	M4/M5
0 580 254 911	95 (4 Bar)	15mm (1/2")	M12 x 1.5	199	52	5.2	M4/M5
0 580 254 975	165 (5 Bar)	15mm (1/2")	M12 x 1.5 (F)	180	60	10	M4/M5
0 580 254 979	165 (5 Bar)	M14 x 1.5	M12 x 1.5 (F)	168	60	10	M4/M5
0 580 254 984	165 (5 Bar)	12mm (3/8")	M12 x 1.5 (F)	180	60	10	M4/M5
0 580 464 069	98 (4 Bar)	12mm (3/8")	M12 x 1.5	186	60	7	M4/M5
0 580 464 070	130 (3 Bar)	12mm (3/8")	8mm (5/16")	175	52	6.5	M4/M5
B 261 205 413	200 (8 Bar)	M18 x1.5	M12 x 1.5	196	60	15.5	M5/M6

Cap Nuts, Copper Washers and Banjo Bolts may be required for installation. These can be found in the "Technical Service Parts" section of this catalogue. Replacement "Fuel Pump Check Valves" are also listed there if applicable.

(F) = Female fitting with internal check valve.

* Operating voltage = 12v, test pressures indicated are also suggested maximum operating pressures.
Flow specifications achieved after initial "running in" period of 20 minutes.

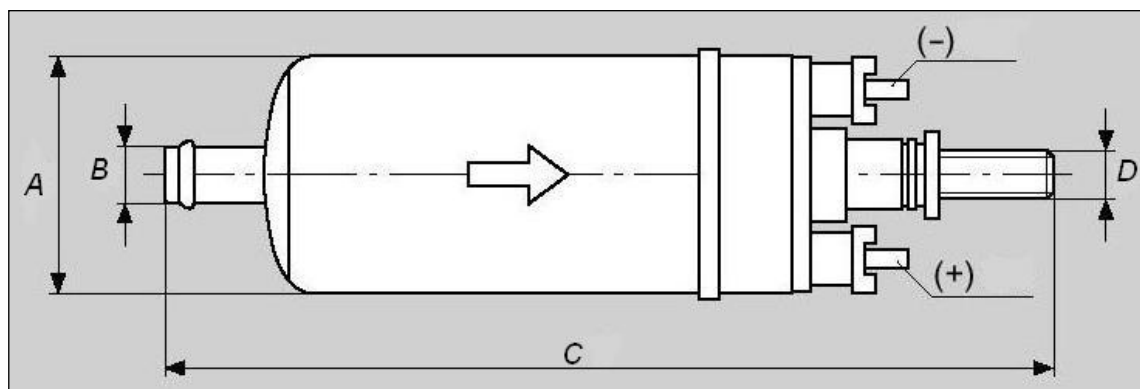

Dimensions

A = Diameter
B = Inlet/Suction Connection Size

C = Length
D = Outlet/Pressure Connection Size

FUEL PUMPS**Notice to Purchaser / Installer**

All Bosch fuel pumps are fully tested and sealed prior to delivery. They are manufactured to the latest design and quality control specifications for their intended application.

Important Information

Always follow the vehicle manufacturers fitting / replacement instructions. Before fitting a fuel pump the following checks should be undertaken.

- Ensure the entire fuel injection system is clean and free from contaminants.
- Ensure that the correct fuse is fitted. [use manufacturers recommendation]
- Inspect and fit a new fuel filter and in-tank strainer to the system. [use only recommended parts]
- Vehicles operating on dual fuel must have a quarter of a tank of petrol at all times.
- It is recommended that the vehicle be operated on petrol at least one day per week to keep the system operating correctly. Failure to operate your vehicle in this way can degrade performance due to stale fuel and the formation of gums and varnish in the fuel system.

Bosch warranty does not cover failure due to the ingress of foreign matter, incorrect application or insufficient fuel supply. All fuel pumps returned under warranty will be inspected prior to claim settlement.

Before fitting new pump

Before fitting a replacement 12v fuel pump, please investigate the reason for the failure of the existing pump and rectify as necessary. Check the current draw of the fuel pump which should be less than 6.5 amps for EFI systems; for K and KE Jetronic systems 11 amps. Excessive current draw or noisy operation can indicate foreign material in the pump roller cell. Use only a fuse having the correct rating as specified by the vehicle manufacturer.

After removing the old pump from the vehicle, empty the contents of the pump into a container. Examine the fuel for signs of foreign material including rust, rubber, varnish, plastic etc. The complete system should be inspected and cleaned if necessary; this includes the fuel tank, fuel rail, pressure regulator, tank pickup unit and strainer.

When refitting the hoses to the pump and fuel filter, take care not to damage the hoses as small rubber particles can circulate through the system and become jammed in the fuel pump, regulator or injector. Fit new fuel pump, check the current draw, check fuel rail pressure.

Bosch warranty does not cover failure that results from the ingress of foreign matter; incorrect application or damage resulting from pumps operating with insufficient fuel in the tank as in LPG conversions.

Fuel Pump FP 100

Fuel delivery: >100 l/h, 5 bar



Description

Fuel delivery	>100 l/h
High temperature reduction	30 l/h
Supply voltage	13,5 V
Current consumption	5 A (5 bar)
Weight	725 g
Non return valve	external

Accessories

Primary connector

Order number

Y 580 701 456

Connections

Intake side	M16 x 1,5
Pressure side	M12 x 1,5
Electrical	+: M4 / -: M5

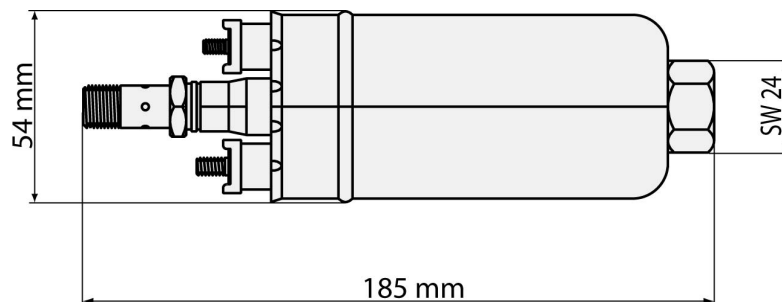

Fuel Pump FP 165

Fuel delivery: >165 l/h, 5 bar



Description	
Fuel delivery	>165 l/h
High temperature reduction	30 l/h
Supply voltage	13,5 V
Current consumption	10 A (5 bar)
Weight	980 g
Non return valve	internal

Accessories	
Primary connector	

Order number	
	0 580 254 979
Offer drawing	A 580 152 325

Connections	
Intake side	M14 x 1,5
Pressure side	M12 x 1,5
Electrical	+: M4 / -: M5

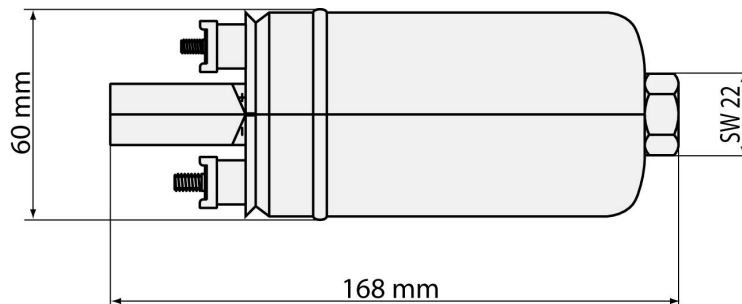

Fuel Pump FP 200

Fuel delivery: >200 l/h, 5/8 bar after a break-in period of 20 h



Description

Fuel delivery	> 200 l/h
High temperature reduction	30 l/h
Supply voltage	13,5 V
Current consumption	13 A
Weight	1030 g
Non return valve	external

Accessories

Primary connector

Order numbers

5 bar	0 580 254 044
8 bar	B 261 205 413
Offer drawing	A 580 152 519

Connections

Intake side	M18 x 1,5
Pressure side	M12 x 1,5
Electrical	+: M6 / -: M5

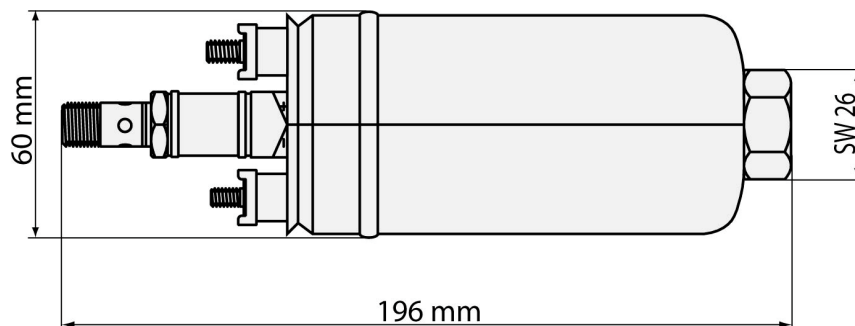

Diesel Fuel Pump DFP 300

Fuel delivery: >300 l/h, 5 bar relative

This electrical diesel fuel pump without non-ferrous metal is especially designed for diesel applications. A modified rotor provides higher fuel delivery than the series version. Its tight housing with screwed connectors fits to any intank or inline fuel circuit. This pump results in an excellent weight-to-power ratio.



Description	
Fuel delivery at fuel temp. < 90 °C	>300 l/h
Fuel delivery increase after break-in period of 20 h	20 l/h
Supply voltage	13,5 V
Current consumption	17,2 A
Weight	700 g
Non return valve	internal
Housing version	inline
Allowed diesel spec.	EN590

Connections	
Intake side	M18 x 1,5
Pressure side	M12 x 1,5
Electrical	+: M6 / -: M5

Order numbers	
DFP 300l/h	B 261 205 366
Offer drawing	A 261 205 366

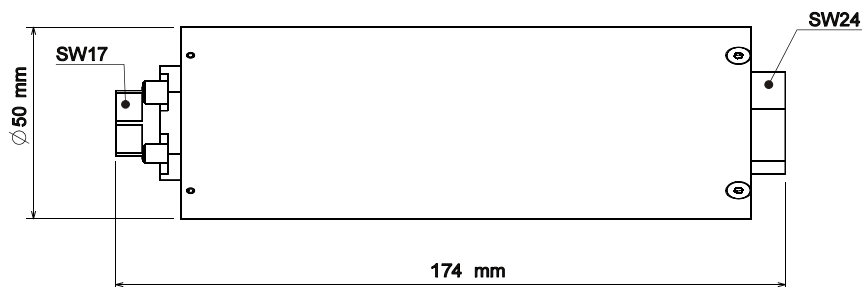

HPI Fuel Pump HDP 1

The HDP 1 is a high pressure radial pump with three pistons. Designing it we set great value on a big delivery volume, as needed in motorsport applications. Variations in bore and stroke affect different deliveries.

This type of pump was used by different 24h-Le Mans winners.

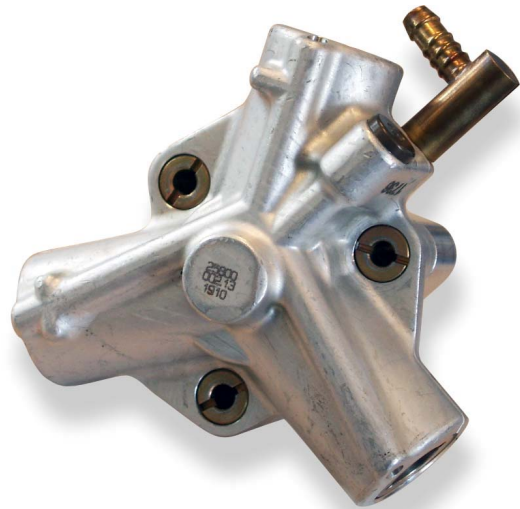

Mechanical data	
Fuel delivery	0,66 ccm/0,80 ccm per rotation
Length	76,8 mm
Weight	1000 g
Enveloping circle	121,4 mm
Supply pressure	4 ... 6 bar
Output pressure	120 bar permanent 200 bar short time
Max. operating temperature	80°C
Max. temperature of location	130°C
Max. rotation per minute	9000

Connections	
Intake side	e.g. thread hole M10 x 1
Pressure side	e.g. thread hole M10 x 1

Order numbers	
Fuel delivery 0,66 ccm	B 438 172 058
Fuel delivery 0,80 ccm	B 438 172 061