

SYSTEM WIRING DIAGRAMS

Cooling Fan Circuit

1991 Volvo 740

For x

Copyright © 1998 Mitchell Repair Information Company, LLC

Friday, July 23, 2004 10:11PM

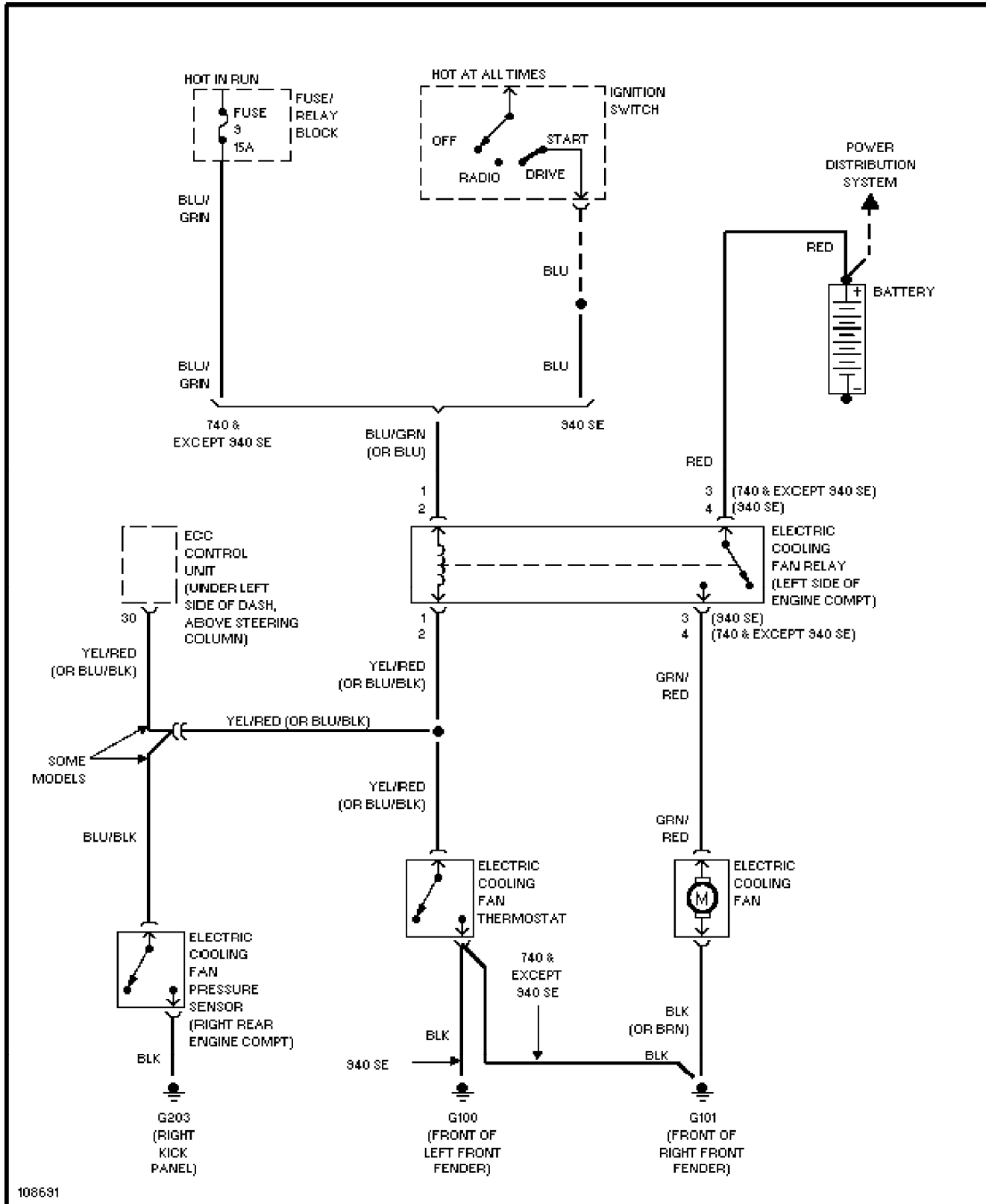

SYSTEM WIRING DIAGRAMS

Front Wiper/Washer Circuit

1991 Volvo 740

For x

Copyright © 1998 Mitchell Repair Information Company, LLC

Friday, July 23, 2004 10:13PM

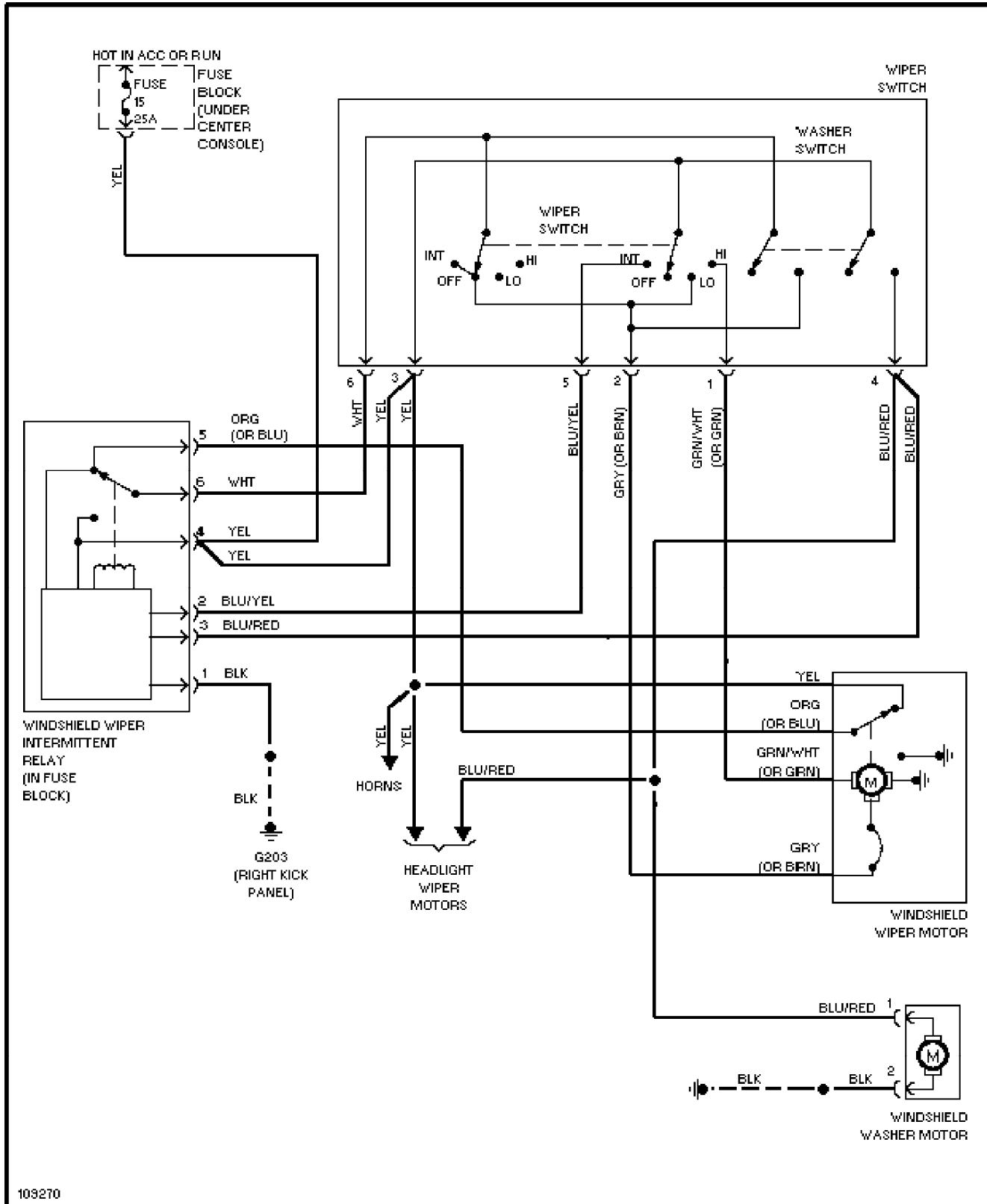

SYSTEM WIRING DIAGRAMS

Headlamp Wiper/Washer Circuit

1991 Volvo 740

For x
 Copyright © 1998 Mitchell Repair Information Company, LLC
 Friday, July 23, 2004 10:13PM

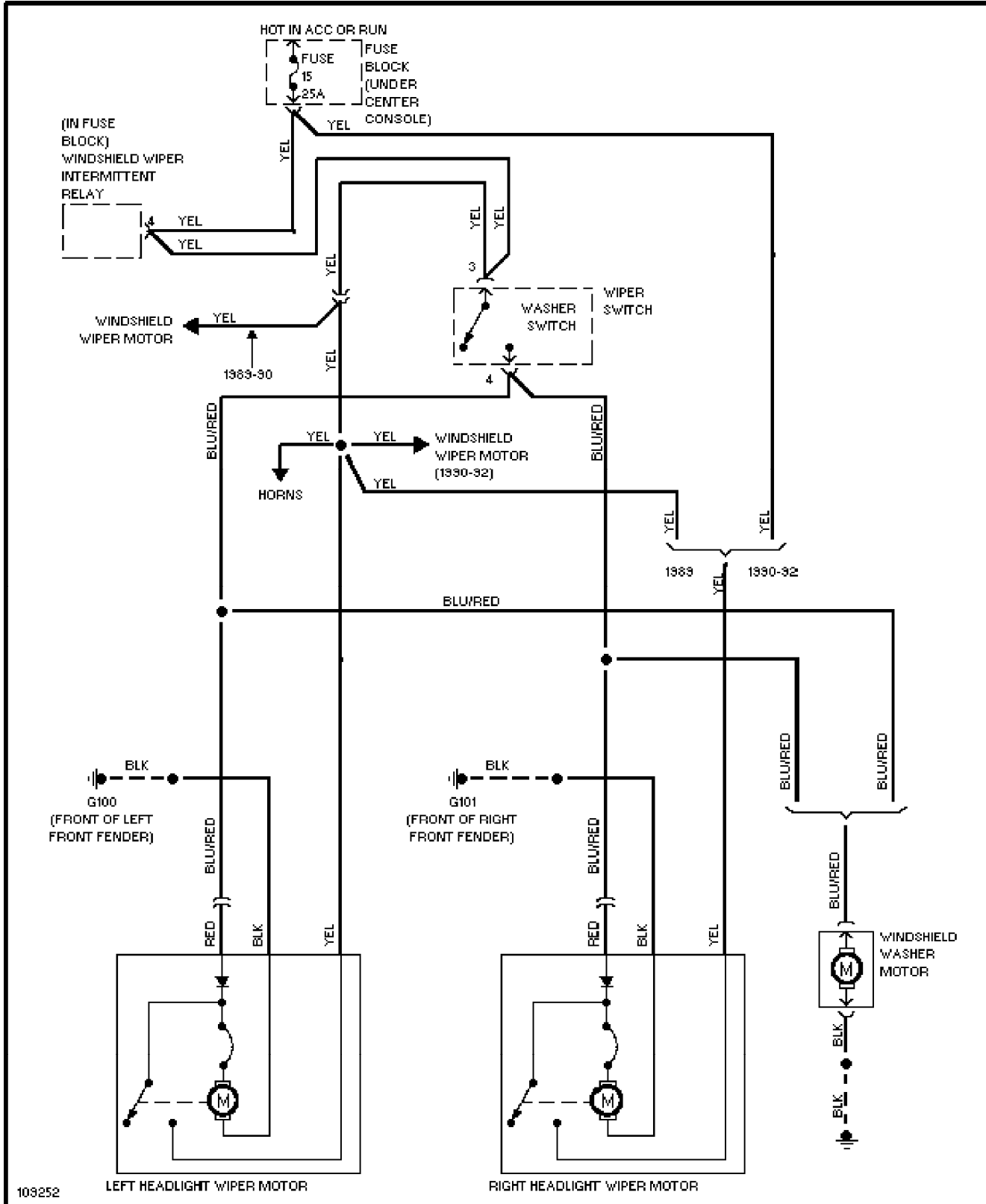

SYSTEM WIRING DIAGRAMS

Rear Wiper/Washer Circuit

1991 Volvo 740

For x

Copyright © 1998 Mitchell Repair Information Company, LLC

Friday, July 23, 2004 10:13PM

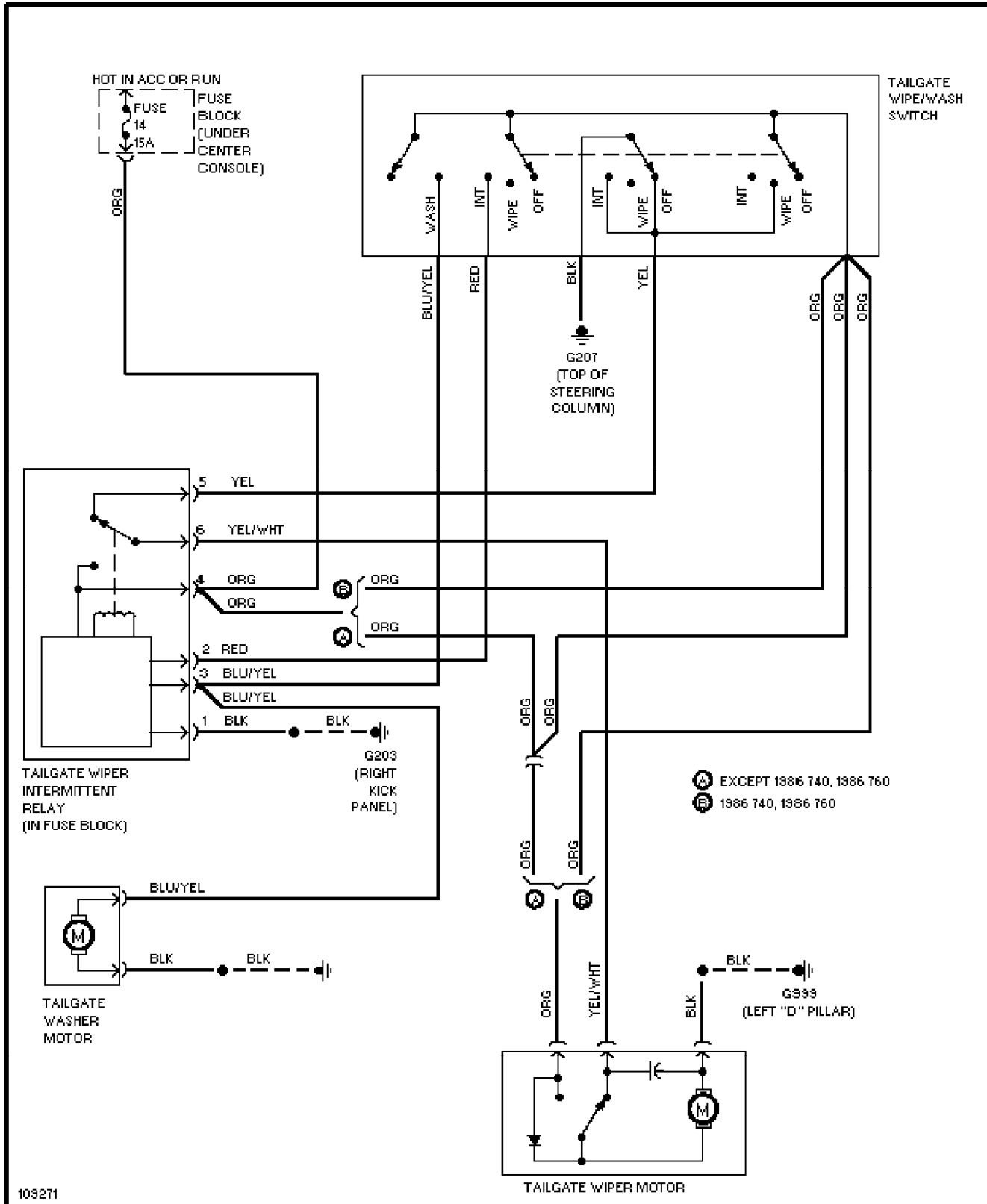

SYSTEM WIRING DIAGRAMS

Defogger Circuit

1991 Volvo 740

For x

Copyright © 1998 Mitchell Repair Information Company, LLC

Friday, July 23, 2004 10:12PM

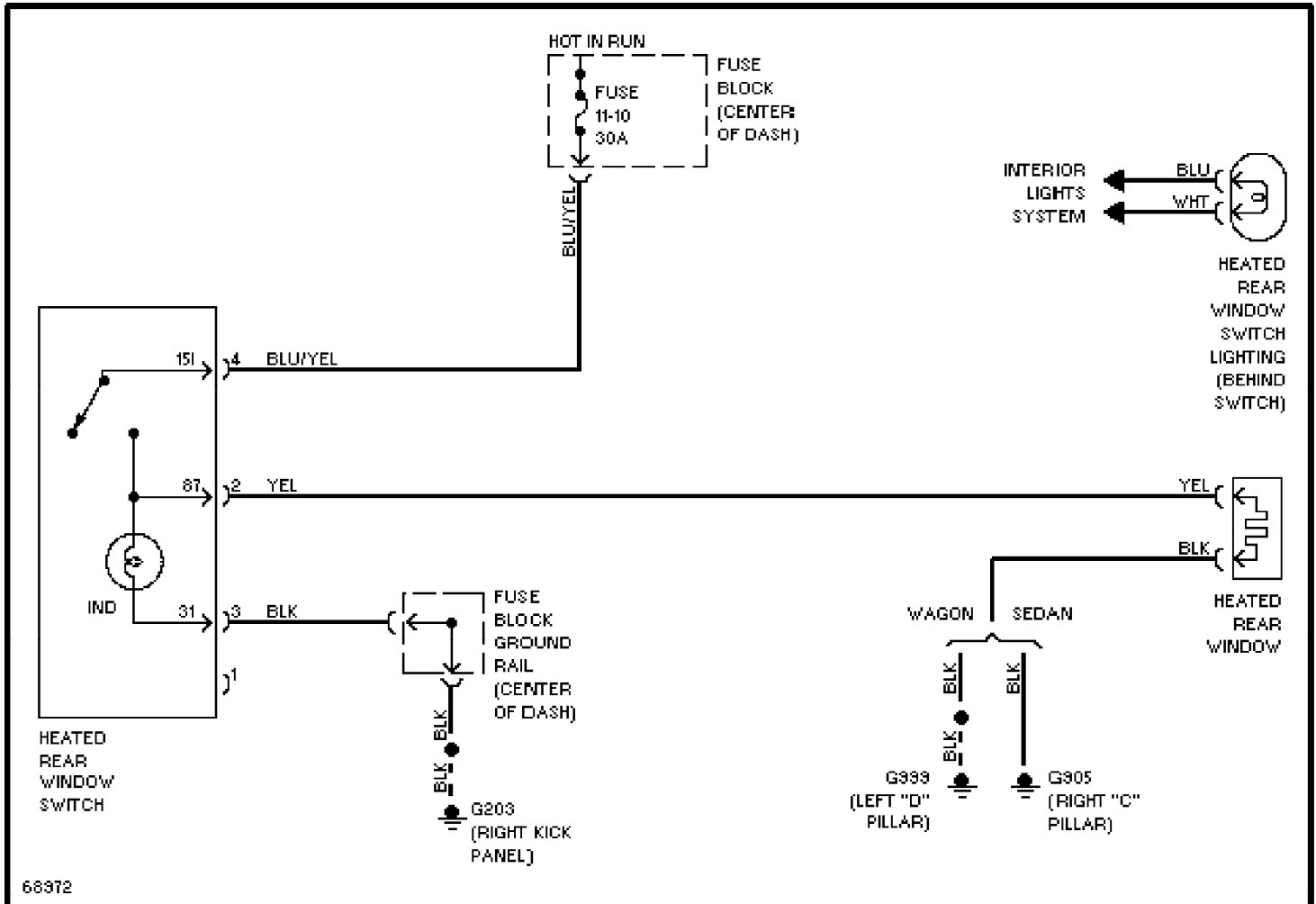

SYSTEM WIRING DIAGRAMS

Rear Defogger & Heated Mirrors Circuit

1991 Volvo 740

For x

Copyright © 1998 Mitchell Repair Information Company, LLC
Friday, July 23, 2004 10:12PM

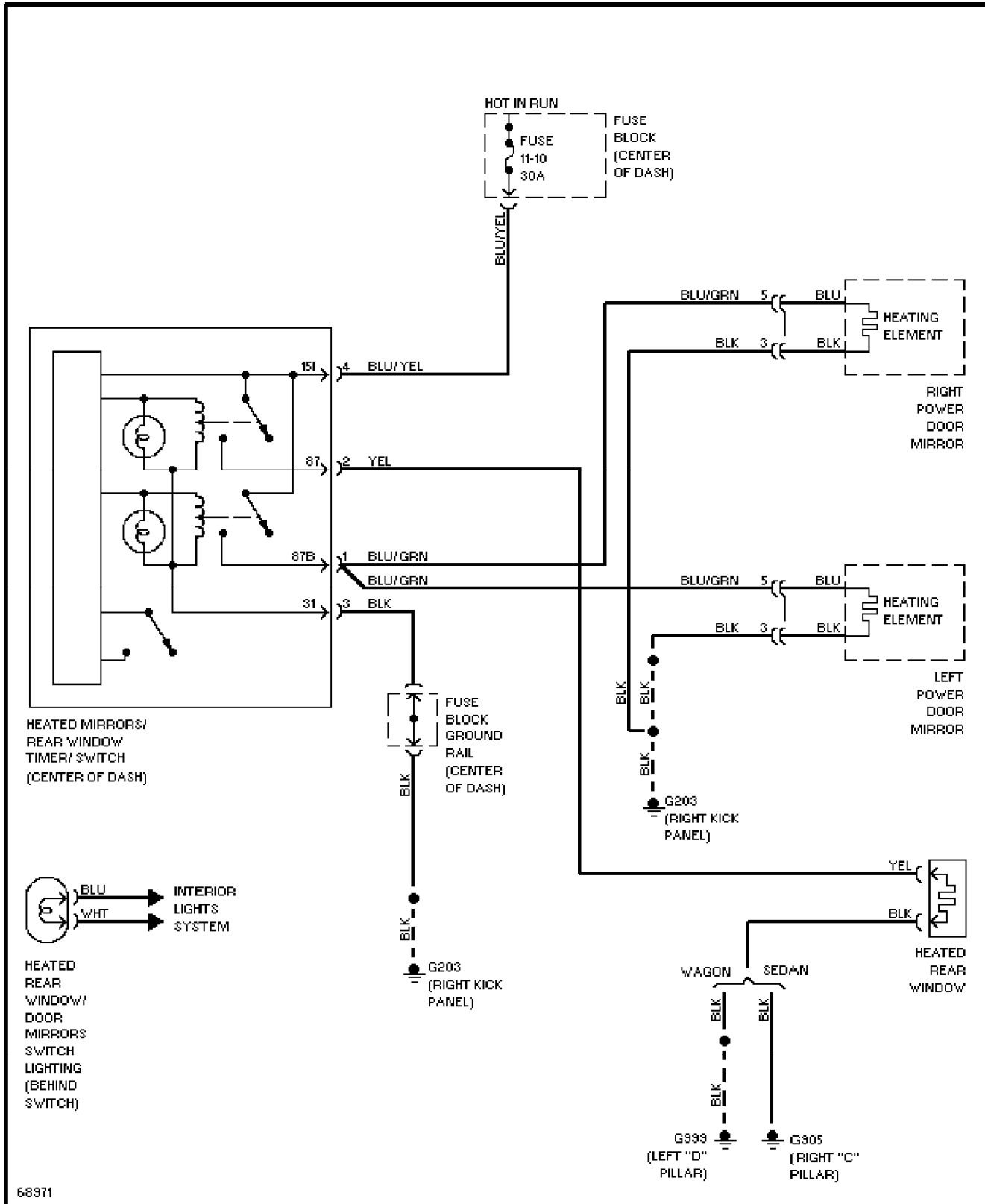

SYSTEM WIRING DIAGRAMS

Horn Circuit

1991 Volvo 740

For x

Copyright © 1998 Mitchell Repair Information Company, LLC

Friday, July 23, 2004 10:12PM

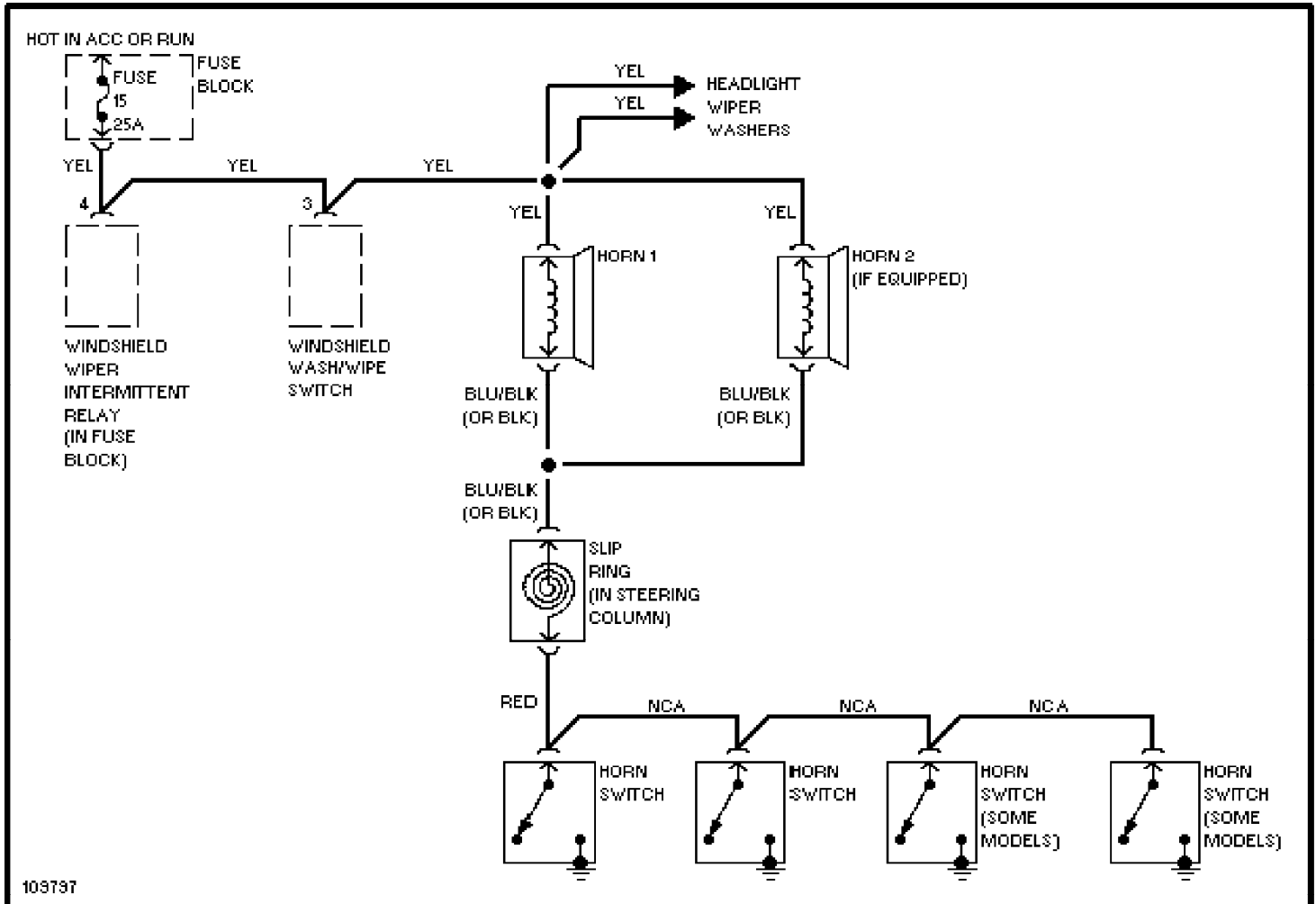

SYSTEM WIRING DIAGRAMS

Power Antenna Circuit

1991 Volvo 740

For x

Copyright © 1998 Mitchell Repair Information Company, LLC

Friday, July 23, 2004 10:12PM

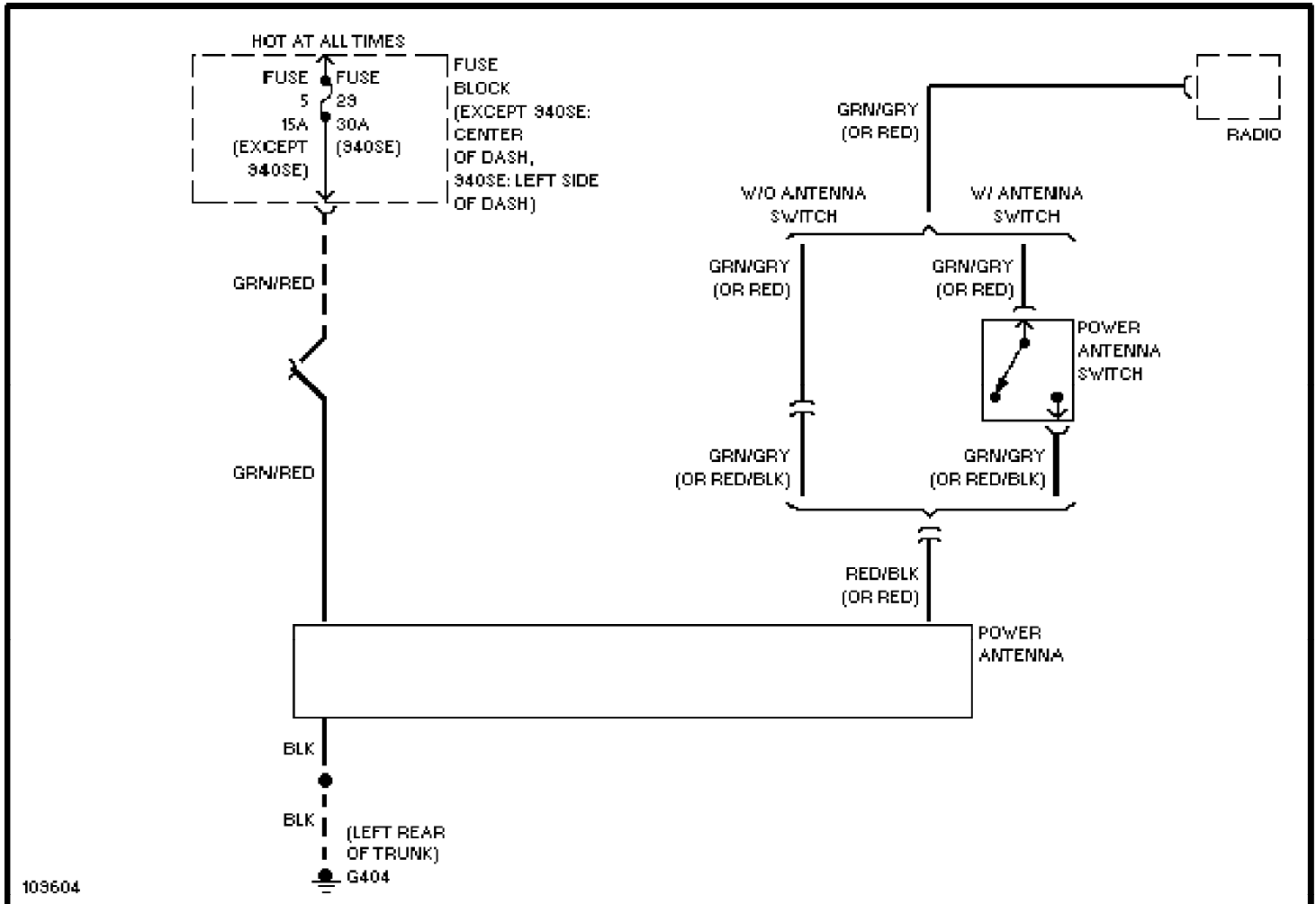

SYSTEM WIRING DIAGRAMS

Power Door Lock Circuit

1991 Volvo 740

For x

Copyright © 1998 Mitchell Repair Information Company, LLC

Friday, July 23, 2004 10:12PM

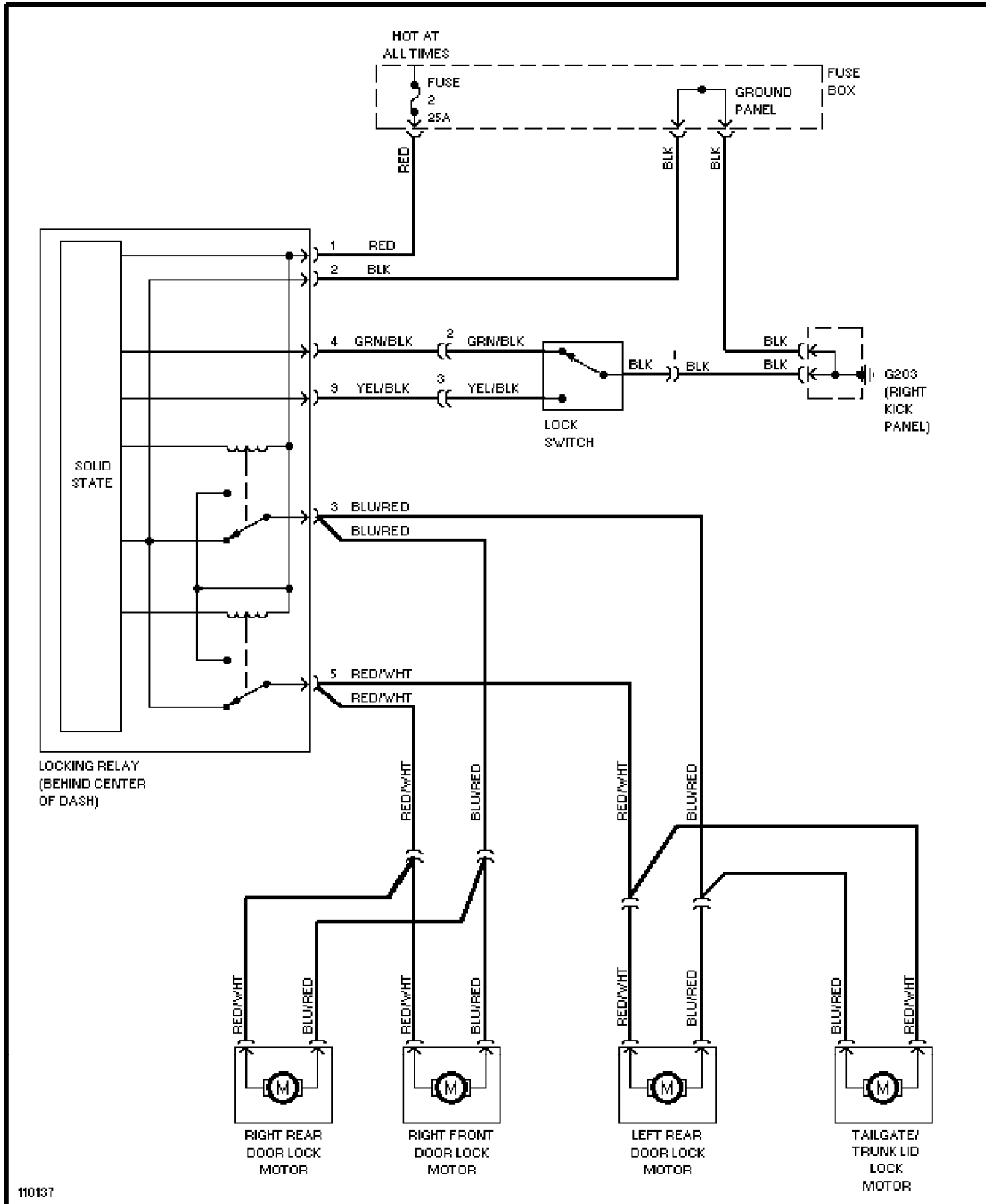

SYSTEM WIRING DIAGRAMS

Power Mirror Circuit

1991 Volvo 740

For x

Copyright © 1998 Mitchell Repair Information Company, LLC

Friday, July 23, 2004 10:12PM

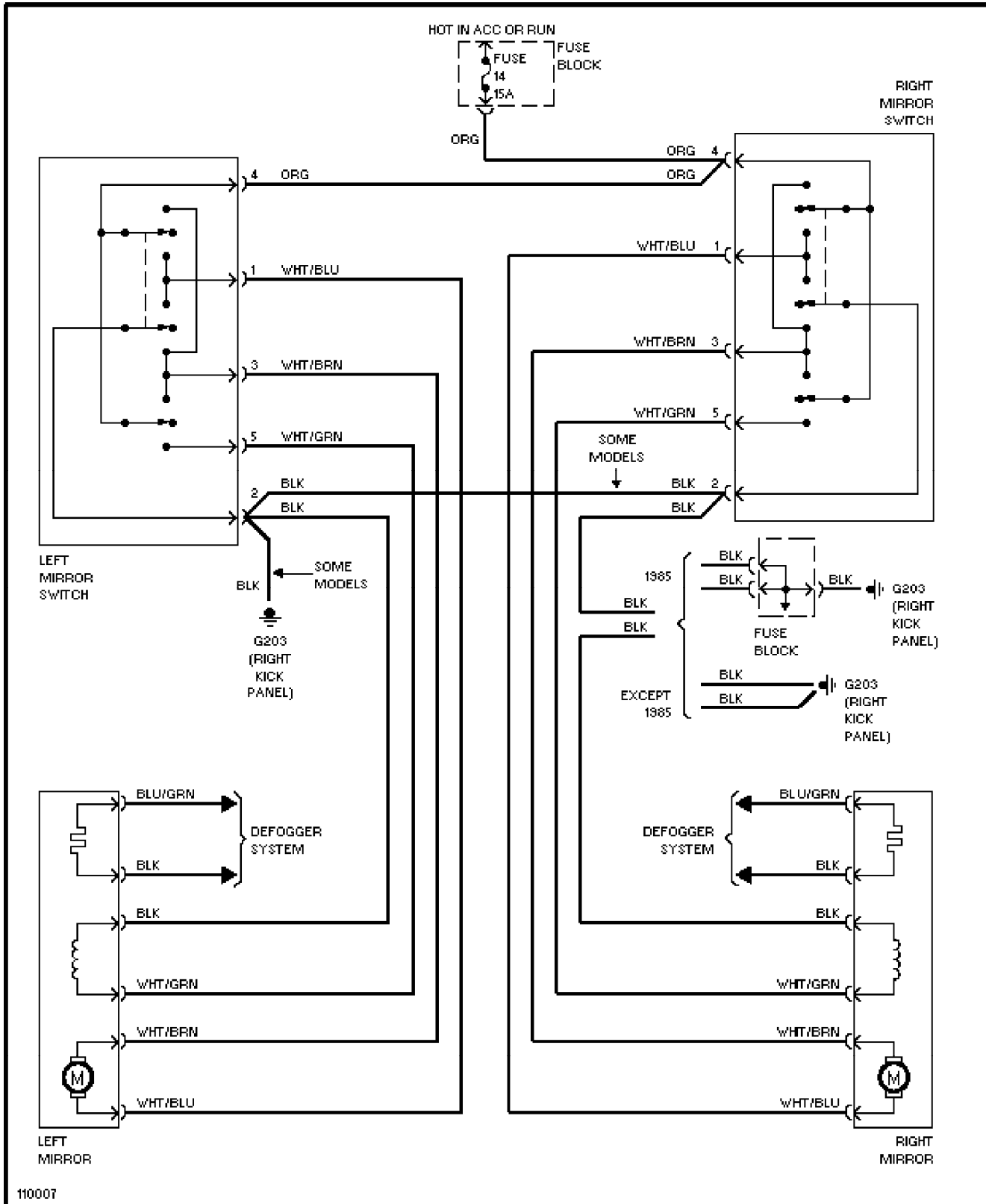

SYSTEM WIRING DIAGRAMS

Heated Seats Circuit, High Output

1991 Volvo 740

For x
Copyright © 1998 Mitchell Repair Information Company, LLC
Friday, July 23, 2004 10:12PM

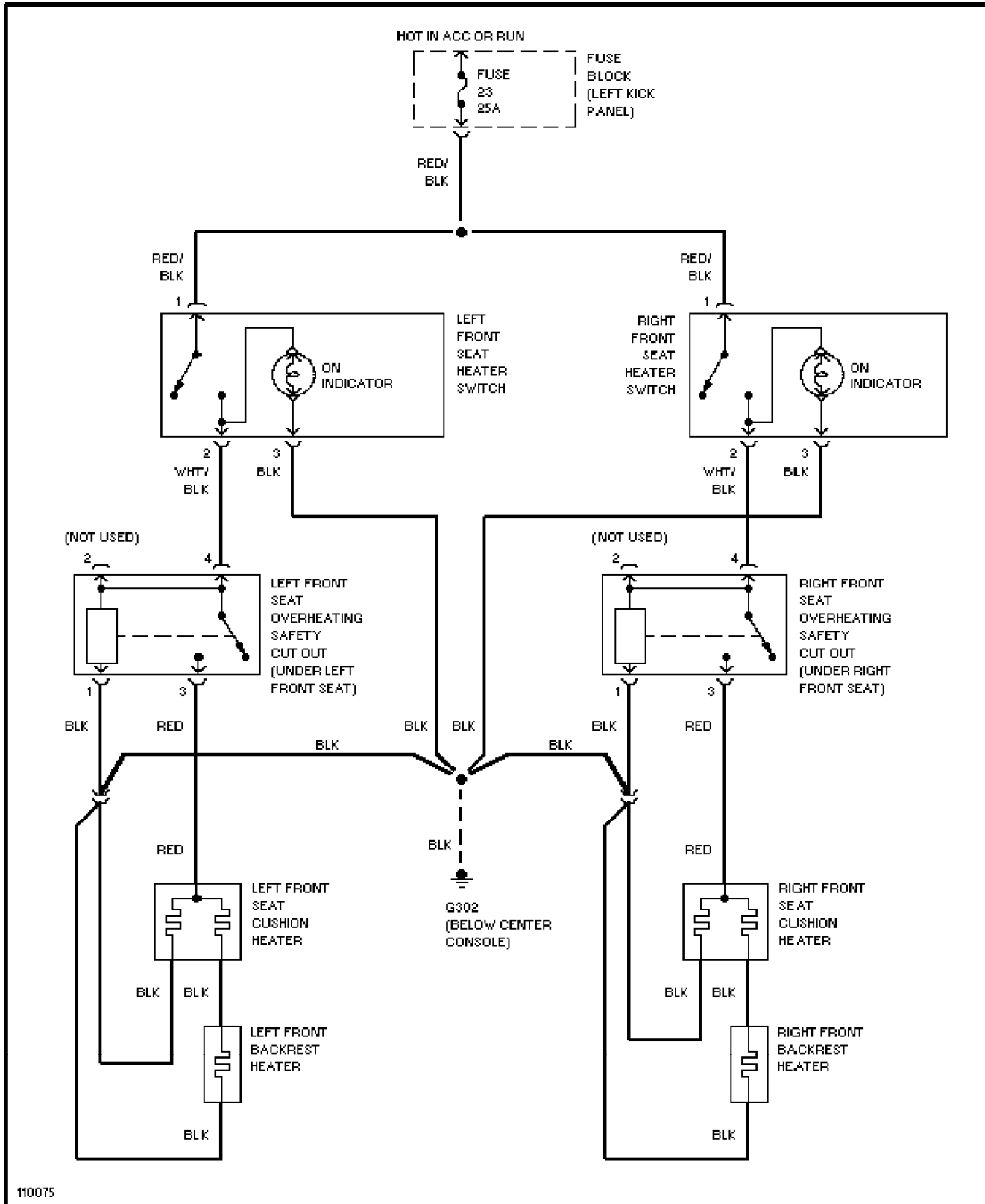

SYSTEM WIRING DIAGRAMS

Heated Seats Circuit, Normal Output

1991 Volvo 740

For x

Copyright © 1998 Mitchell Repair Information Company, LLC
Friday, July 23, 2004 10:12PM

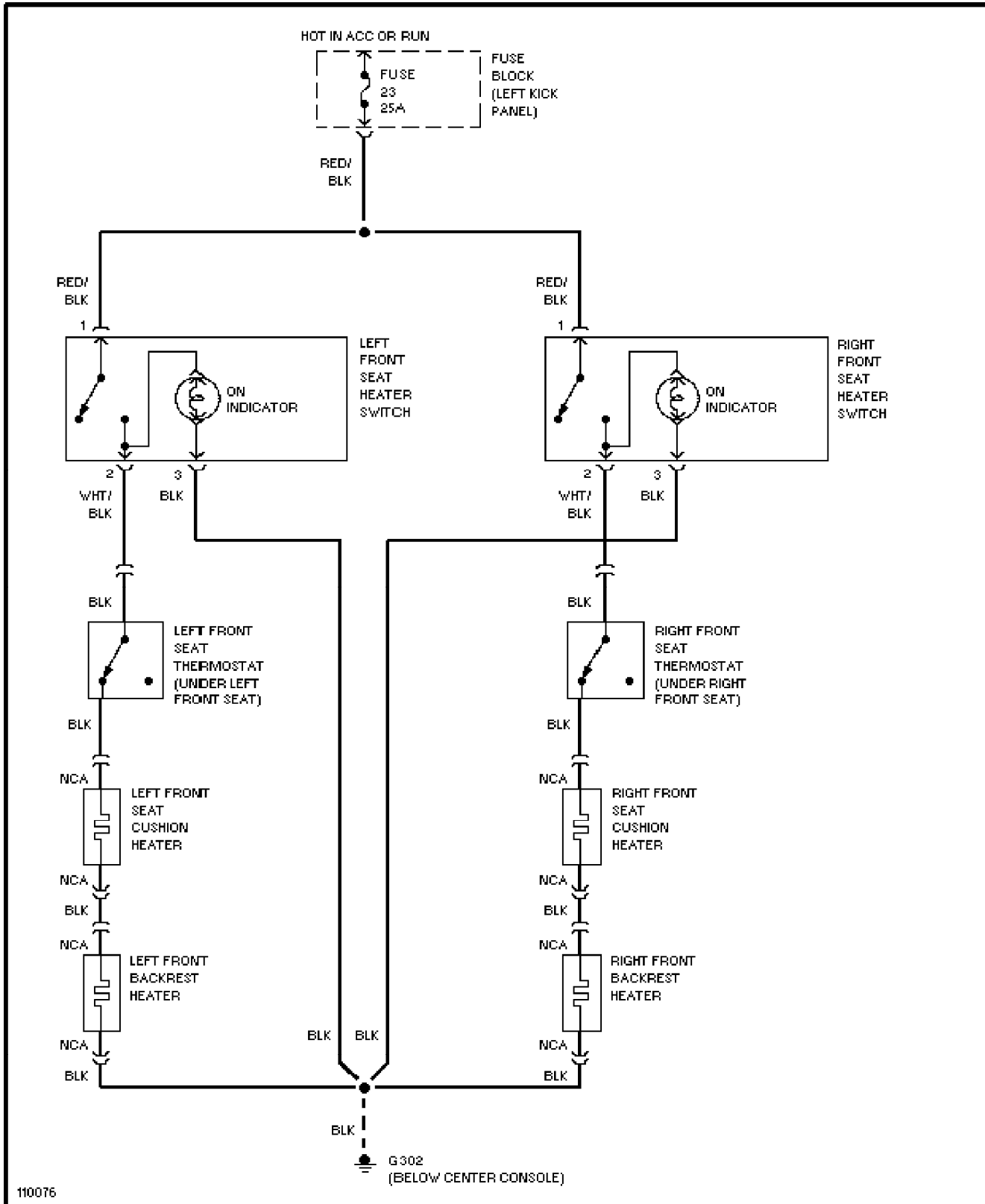

SYSTEM WIRING DIAGRAMS

Power Seats Circuit

1991 Volvo 740

For x

Copyright © 1998 Mitchell Repair Information Company, LLC

Friday, July 23, 2004 10:12PM

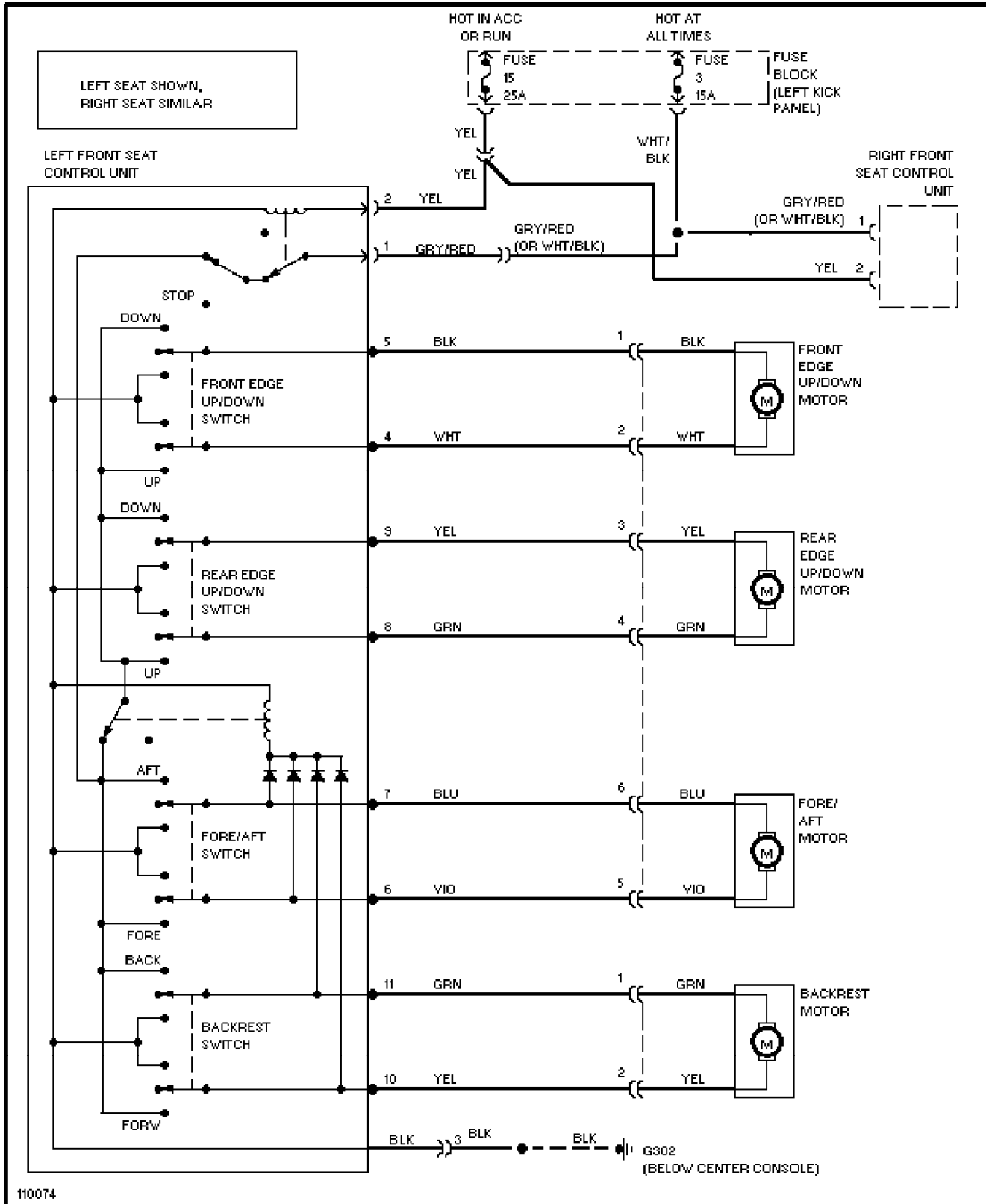

SYSTEM WIRING DIAGRAMS

Power Window Circuit

1991 Volvo 740

For x

Copyright © 1998 Mitchell Repair Information Company, LLC

Friday, July 23, 2004 10:12PM

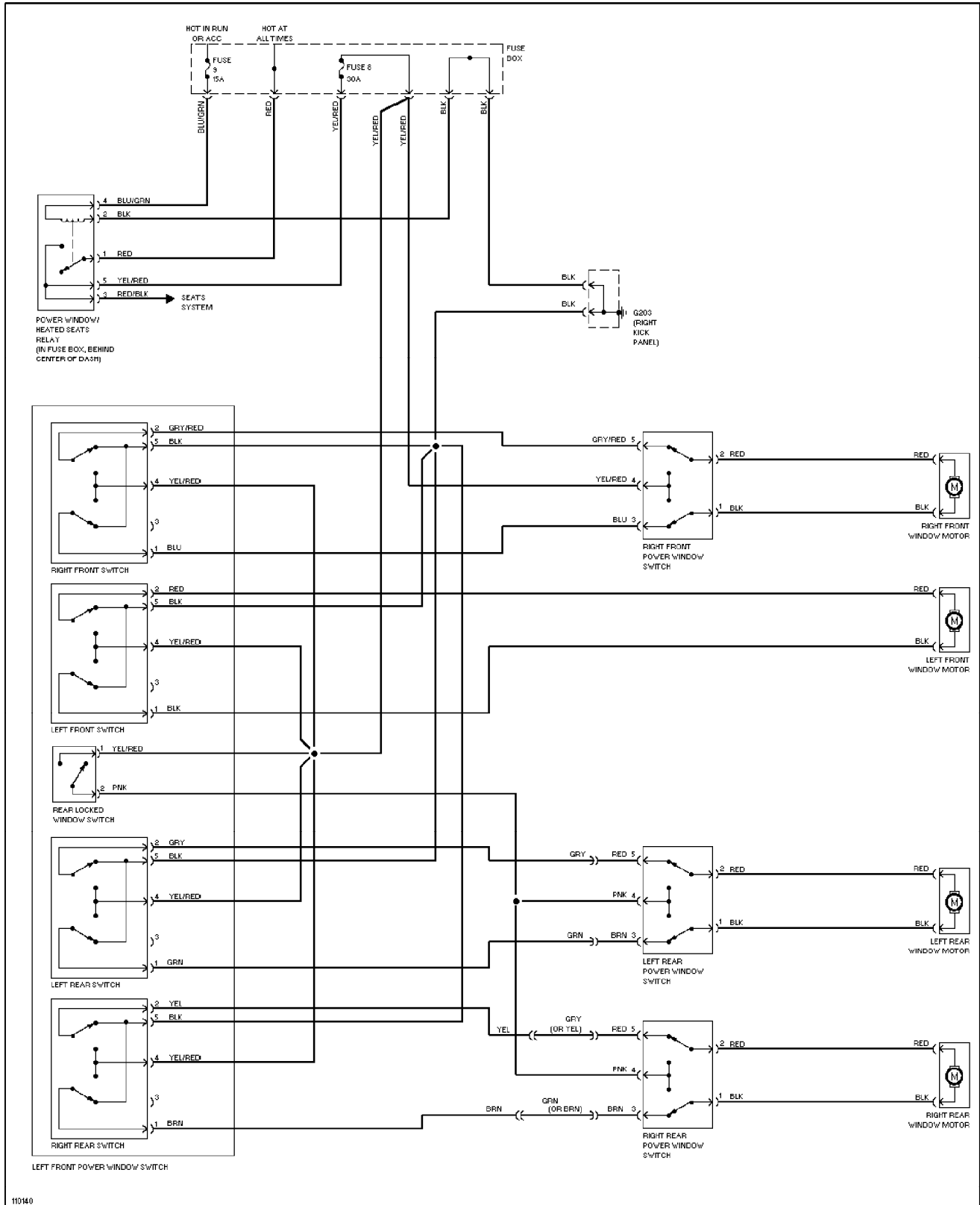

SYSTEM WIRING DIAGRAMS

Radio Circuits

1991 Volvo 740

For x

Copyright © 1998 Mitchell Repair Information Company, LLC

Friday, July 23, 2004 10:12PM

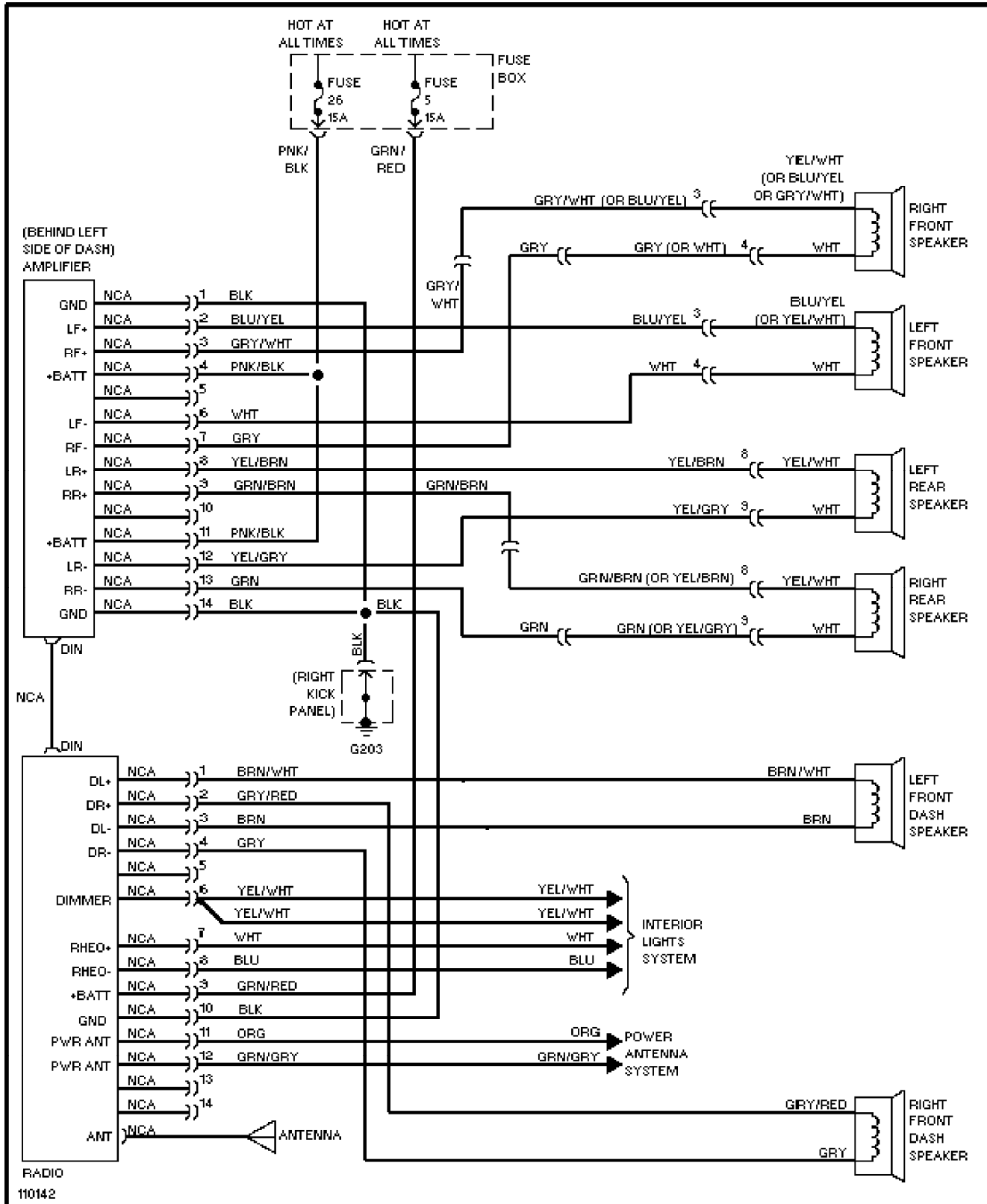

SYSTEM WIRING DIAGRAMS

Starting Circuit

1991 Volvo 740

For x

Copyright © 1998 Mitchell Repair Information Company, LLC

Friday, July 23, 2004 10:13PM

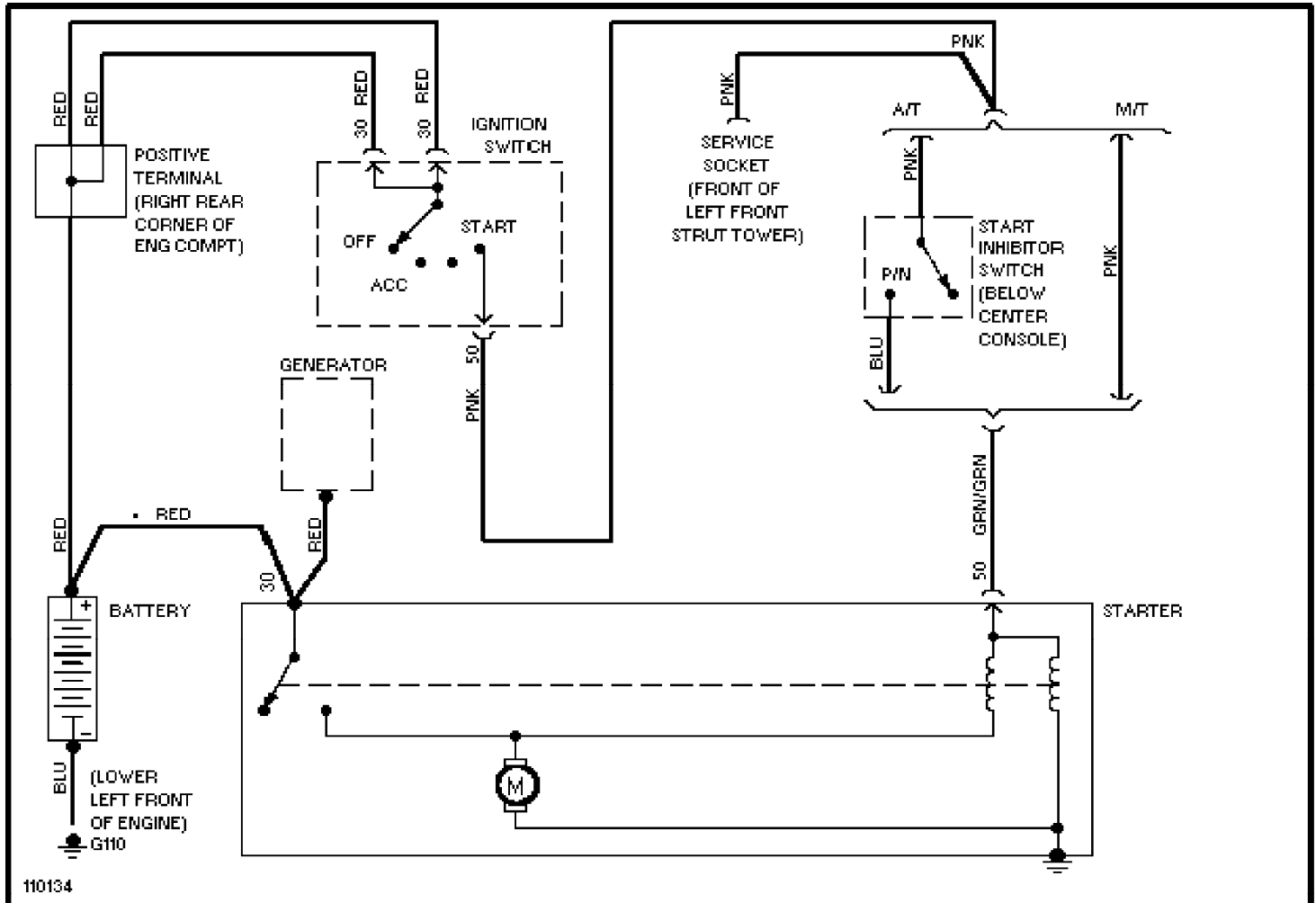

WIRING DIAGRAMS

Fig. 10: Pwr Windows/Heated Seats (Grid 36-39)

1991 Volvo 740

For x

Copyright © 1998 Mitchell Repair Information Company, LLC
Friday, July 23, 2004 10:15PM

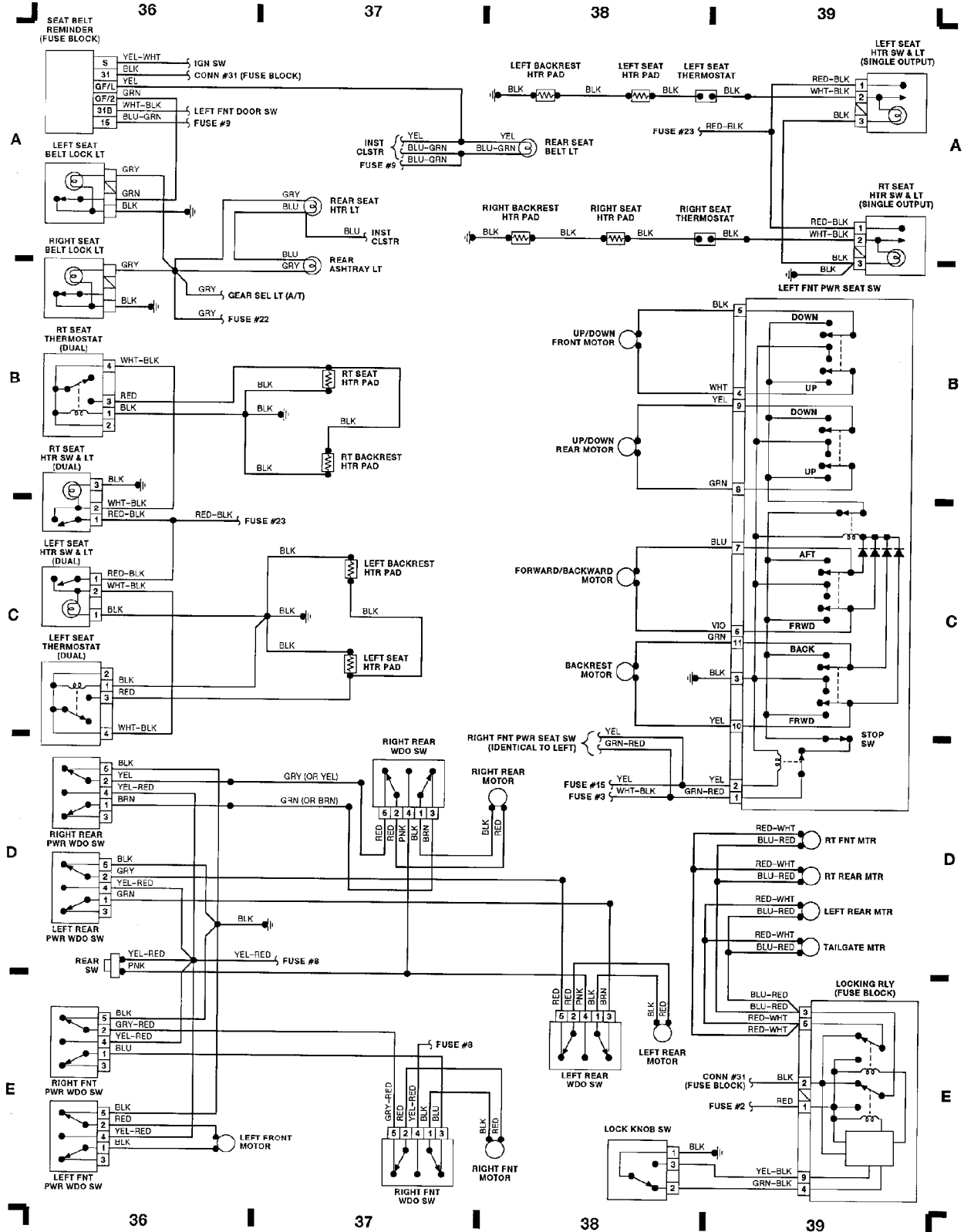

WIRING DIAGRAMS

Fig. 11: Power Mirror, Defog Sw, Taillights (Grids 40-43)

1991 Volvo 740

For x

Copyright © 1998 Mitchell Repair Information Company, LLC

Friday, July 23, 2004 10:15PM

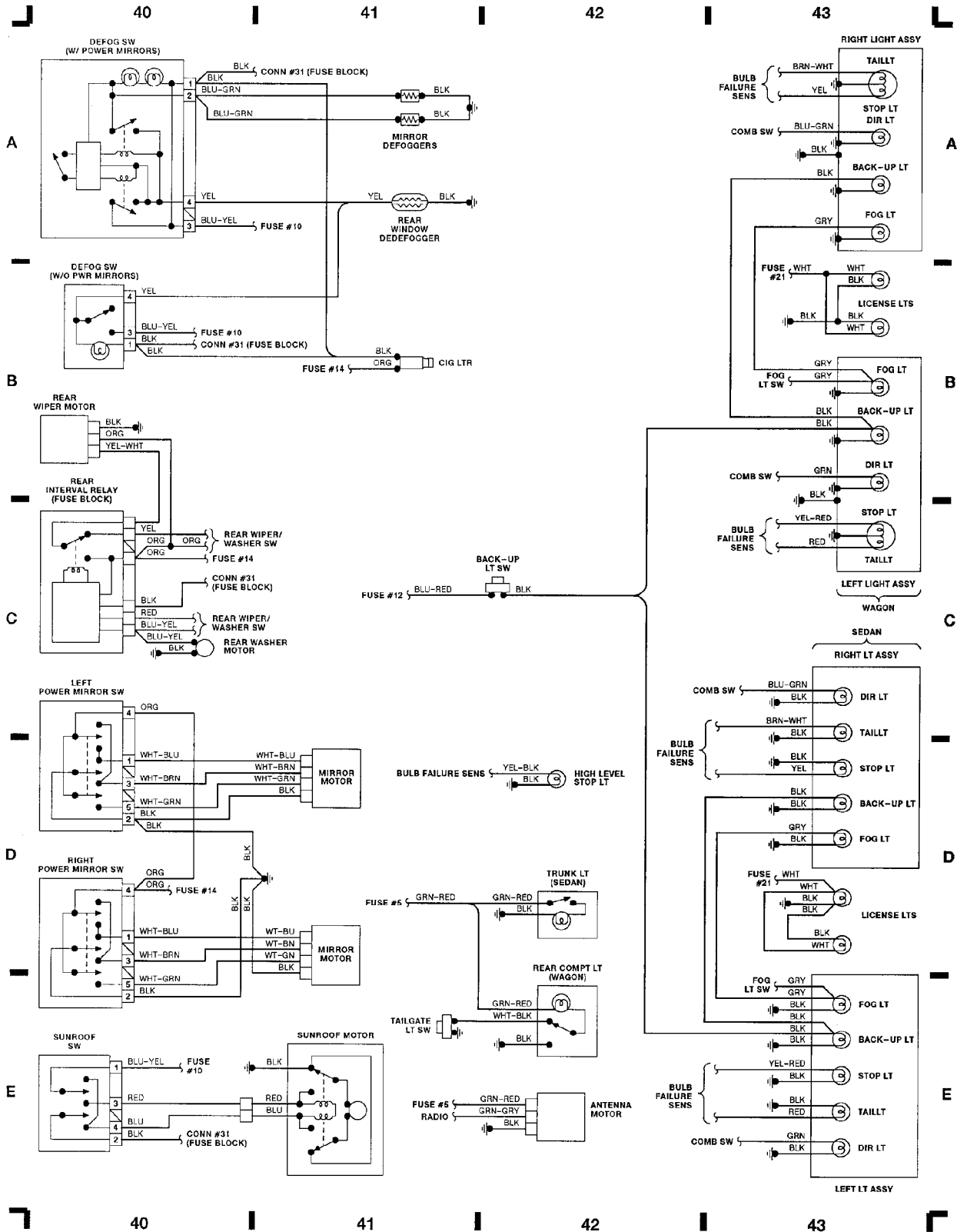

WIRING DIAGRAMS

Fig. 1: Engine Compartment, Fuses & Headlights (Grids 1-3)

1991 Volvo 740

For x

Copyright © 1998 Mitchell Repair Information Company, LLC

Friday, July 23, 2004 10:15PM

COMPONENT LOCATOR:

ABS CTRL UNIT	A 29-30
ABS MODULATOR	A-C 31
ALTERNATOR	C 3
BACK-UP LT SW	C 42
BATTERY	A 2
BEAM LENGTH REGULATOR	A 19
BULB FAILURE SENS	E 24
CHG LTR	B 41
COMB SW	A-C 24
COOLANT FAN RELAY	A 18-18
COURTESY LTS	C 24
CRUISE CTRL SYS	C-J 28-30
DEFOG SYS	A-B 40-41
DOOR LTS	D 24
ECC CTRL UNIT	C-E 23
ECC POWER UNIT	E 20
FLASHER RELAY	A 27
FOG LT RELAY	E 28
FOG LT SW	C-E 28
FUEL INJ ECU (CALIF)	A-C 4
FUEL INJ ECU (REGINA)	A-C 12
FUEL INJ ECU (TURBO)	A-B 8
FUEL PUMP (IN TANK) (CALIF)	D 4
FUEL PUMP (IN TANK) (TURBO)	C 11
FUEL PUMP (MAIN) (CALIF)	D 12
FUEL PUMP (MAIN) (TURBO)	C 4
FUEL PUMP (REGINA)	C 12
FUEL SYS RELAY (CALIF)	B 11
FUEL SYS RELAY (REGINA)	B 11
FUEL SYS RELAY (TURBO)	B 11
FUSE/RELAY BLOCK (PARTIAL)	B-D 16-19
GEAR SEL LT	C 35
GLOVE BOX LT	C 20
HEATER CTRL SW	D 42
HIGH LEVEL STOP LT	C 1-2
HORN & HORN SWS	E 6
IGN COIL (CALIF)	E 15
IGN COIL (REGINA)	C 8
IGN COIL (TURBO)	E 16
IGN SW	C-D 7
IGN SYS ECU (CALIF)	C-D 15
IGN SYS ECU (REGINA)	D-E 8
IGN SYS ECU (TURBO)	D-E 8
INHIBITOR SW (M/T)	A-E 32-33
INST CLSTR	E 35
INTVL RELAY	D 27
JUNCTION BLOCK	A-B 2-3
LEFT FRONT DOOR SW	C 26
LEFT HEADLT ADJUSTING MTR	C-D 1
LEFT HEADLT WIPER MOTOR	E 3
LIGHT RELAY	B-C 27
LIGHT SW	A-B 27
LOCKING RELAY	D-E 30-39
MCC CTRL UNIT	B-C 23
O/D RELAY (A/T)	B 20
O/D RELAY (M/T)	A 20
O2 SENS (CALIF)	C 7
O2 SENS (REGINA)	C 15
POWER ANTENNA MOTOR	E 42
POWER MIRROR SYS	C-E 40-41
POWER SEAT SW	B-D 36-39
POWER WINDOW SYS	D-E 36-39
POWER WINDOW/HEATED SEAT RELAY	C 29
RADIO INTERFERENCE SUPPRESSION RELAY (CALIF)	B 7
RADIO INTERFERENCE SUPPRESSION RELAY (TURBO)	D 11
REAR INTERVAL RELAY	C 40
REAR WIPER/WASHER SW	D-E 27
RHEOSTAT & CLOCK ADJUSTER	C-D 35
RIGHT HEADLT ADJUSTING MOTOR	B 1
RIGHT HEADLT WIPER MOTOR	E 3
SEAT BELT LOCK LTS	A-B 36
SEAT BELT REMINDER	A 36
SEAT HEATER SYS (DUAL)	B-C 36-37
SEAT HEATER SYS (SINGLE OUTPUT)	A 38-39
SHIFT LOCK SYS	E 31
SRS SYS	C-D 31
STARTER	B-C 2
STOP LT SW	D 28
SUNROOF SYS	E 40-41
TRANSIENT SURGE PROTECTOR	B 28
TRUNK LT	D-E 41-42
WIPER MOTOR	D 3
WIPER/WASHER SW	C 27

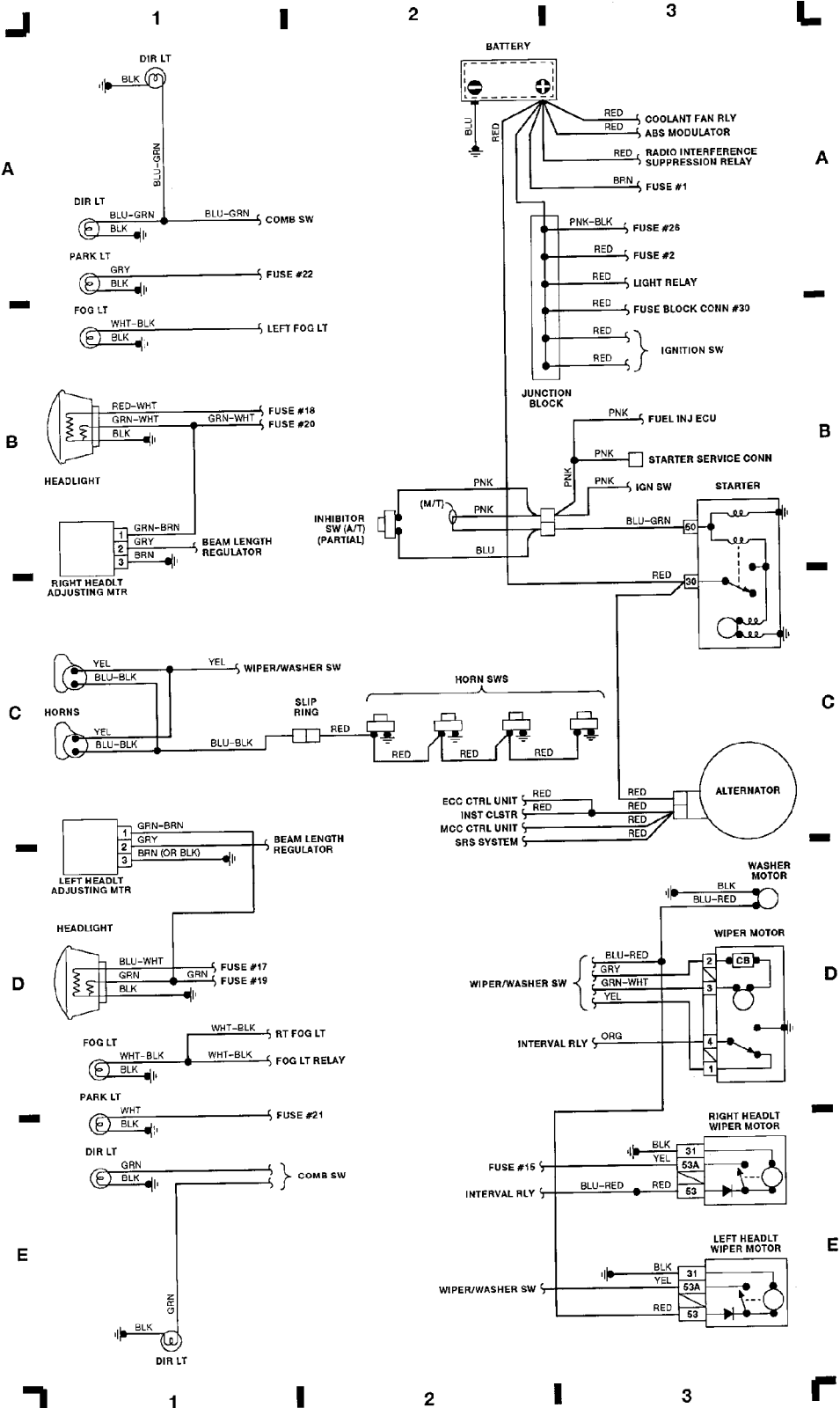

WIRING DIAGRAMS

Fig. 2: Computer Engine Control (Calif.) (Grids 4-7)

1991 Volvo 740

For x

Copyright © 1998 Mitchell Repair Information Company, LLC
Friday, July 23, 2004 10:15PM

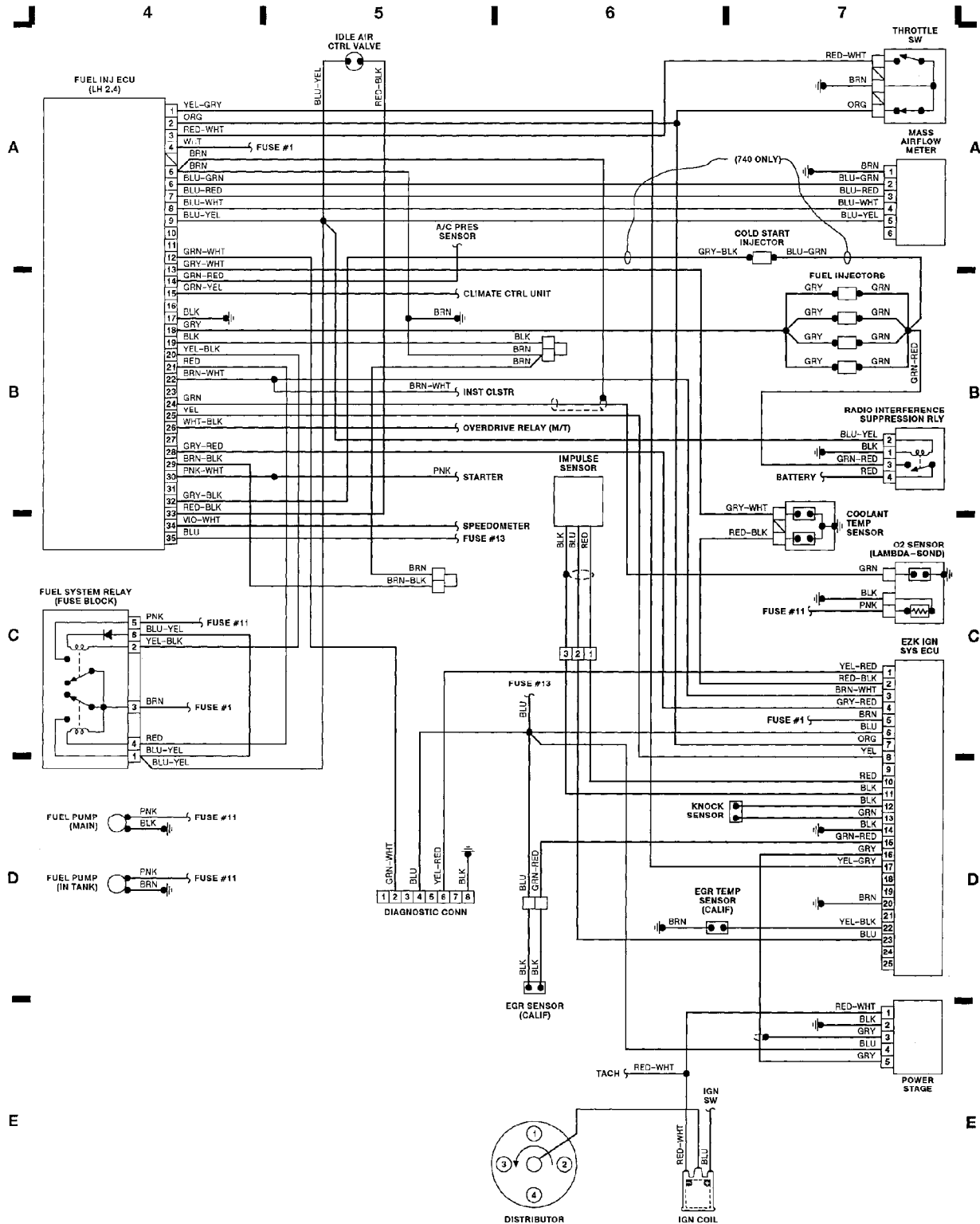

WIRING DIAGRAMS

Fig. 3: Computer Eng Control (Turbo) (Grids 8-11)

1991 Volvo 740

For x

Copyright © 1998 Mitchell Repair Information Company, LLC

Friday, July 23, 2004 10:15PM

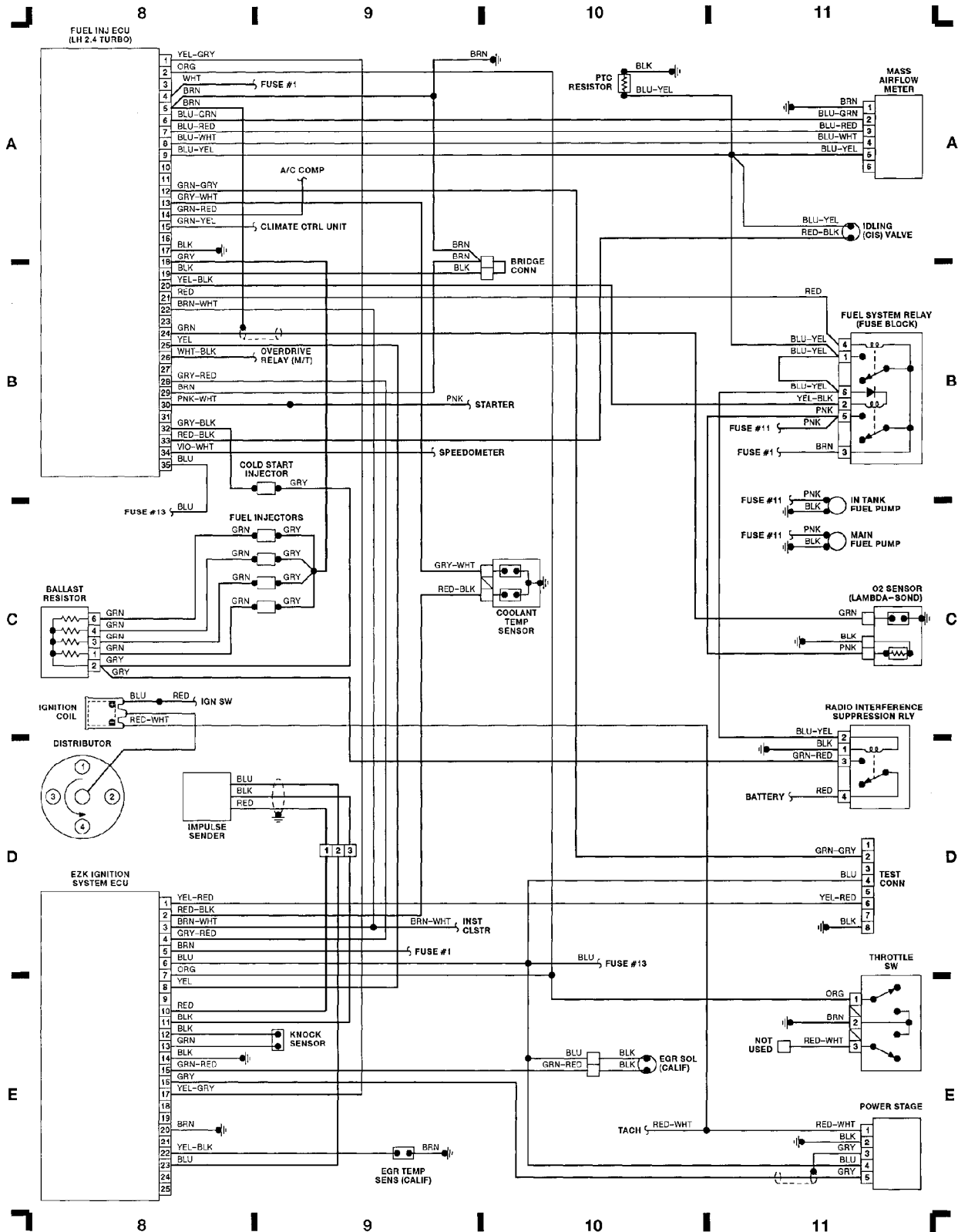

WIRING DIAGRAMS

Fig. 4: Computer Eng Control (Regina) (Grids 12-15)

1991 Volvo 740

For x
Copyright © 1998 Mitchell Repair Information Company, LLC
Friday, July 23, 2004 10:15PM

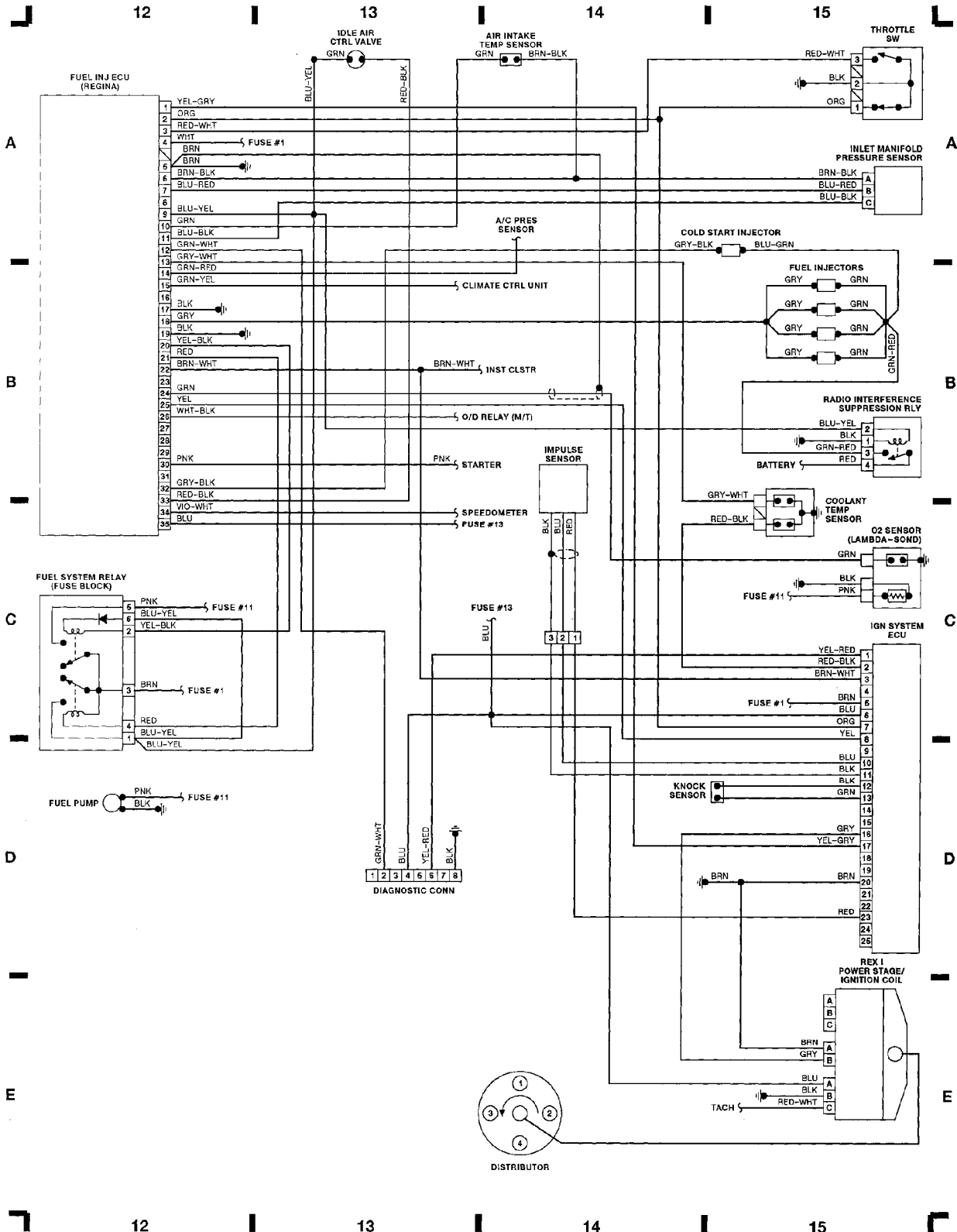

WIRING DIAGRAMS

Fig. 5: A/C System (Grids 16-19)

1991 Volvo 740

For x

Copyright © 1998 Mitchell Repair Information Company, LLC
Friday, July 23, 2004 10:15PM

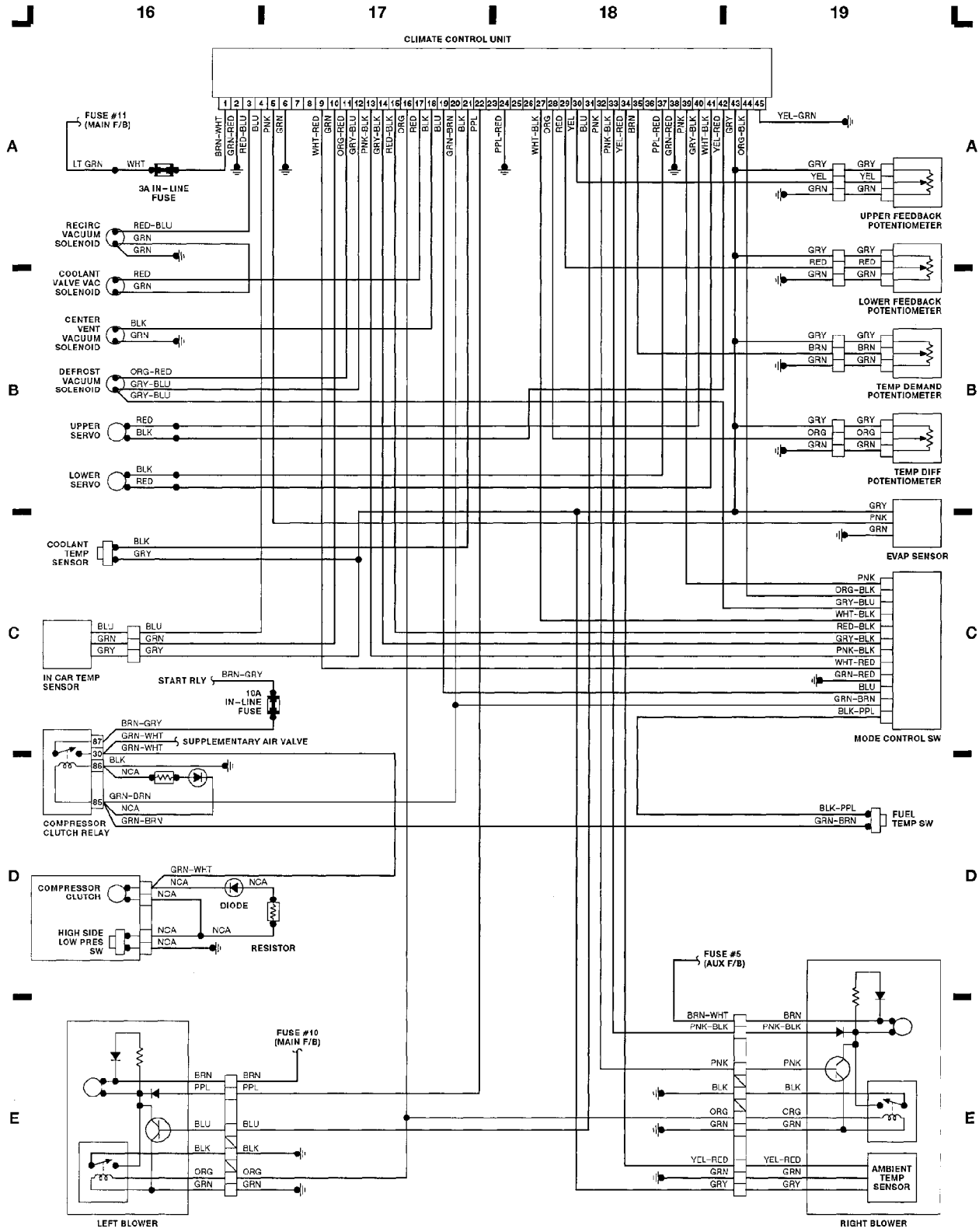

WIRING DIAGRAMS
Fig. 6: ECC Ctrl Unit, MCC Ctrl Unit (Grids 20-23)
 1991 Volvo 740
 For x
 Copyright © 1998 Mitchell Repair Information Company, LLC
 Friday, July 23, 2004 10:15PM

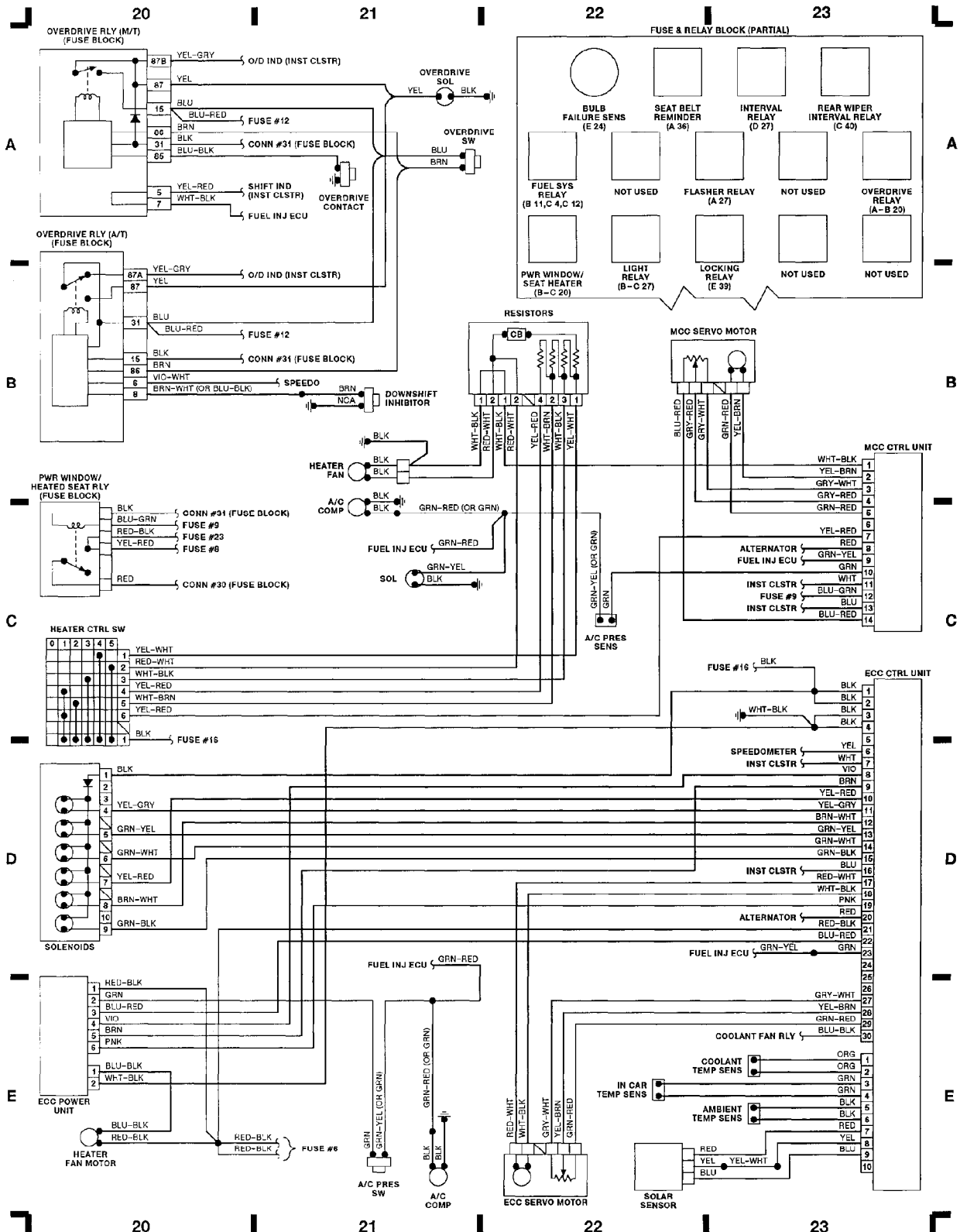

WIRING DIAGRAMS

Fig. 7: Comb Sw, Wiper/Washer Sw, Courtesy Sw (Grids 24-27)

1991 Volvo 740

For x

Copyright © 1998 Mitchell Repair Information Company, LLC

Friday, July 23, 2004 10:15PM

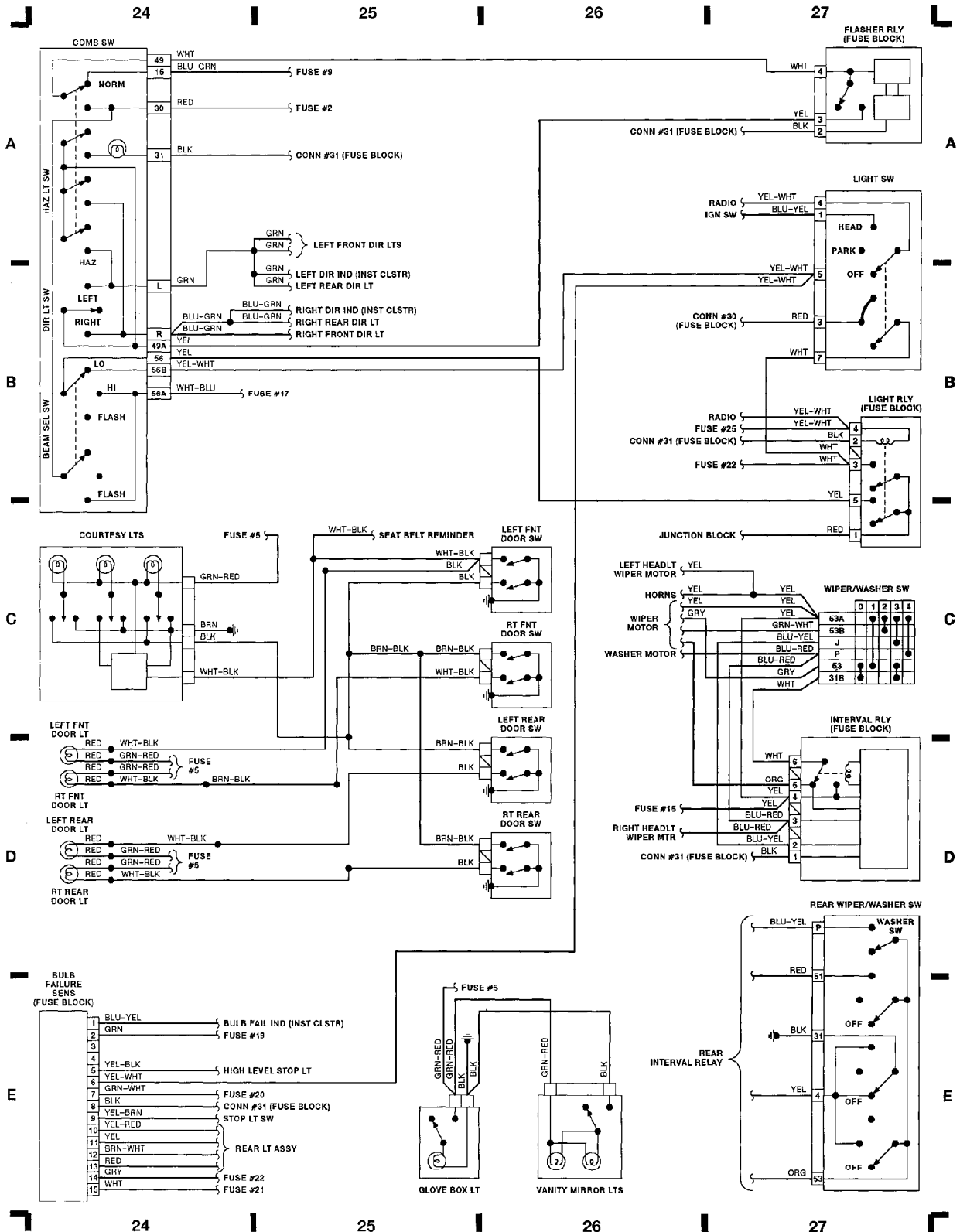

WIRING DIAGRAMS

Fig. 8: ABS Ctrl, Cruise Ctrl, Trans Surge Protector (Grids 28-31)

1991 Volvo 740

For x

Copyright © 1998 Mitchell Repair Information Company, LLC

Friday, July 23, 2004 10:15PM

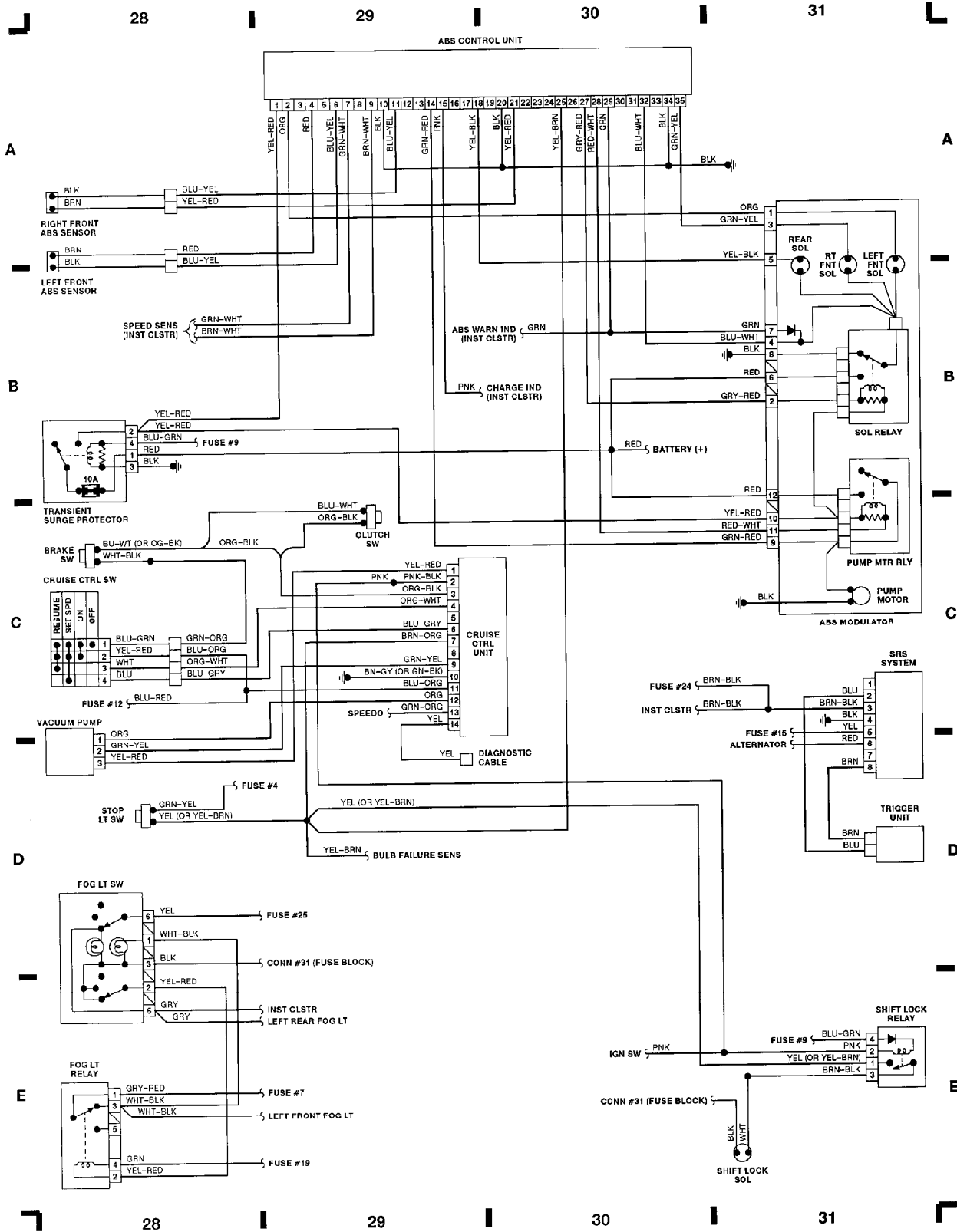

WIRING DIAGRAMS
Fig. 9: Inst Cluster, Rheostat (Grids 32-35)
 1991 Volvo 740
 For x
 Copyright © 1998 Mitchell Repair Information Company, LLC
 Friday, July 23, 2004 10:15PM

