

# SYSTEM WIRING DIAGRAMS

## Cooling Fan Circuit

1988 Volvo 760

For x

Copyright © 1998 Mitchell Repair Information Company, LLC

Friday, July 23, 2004 08:49PM

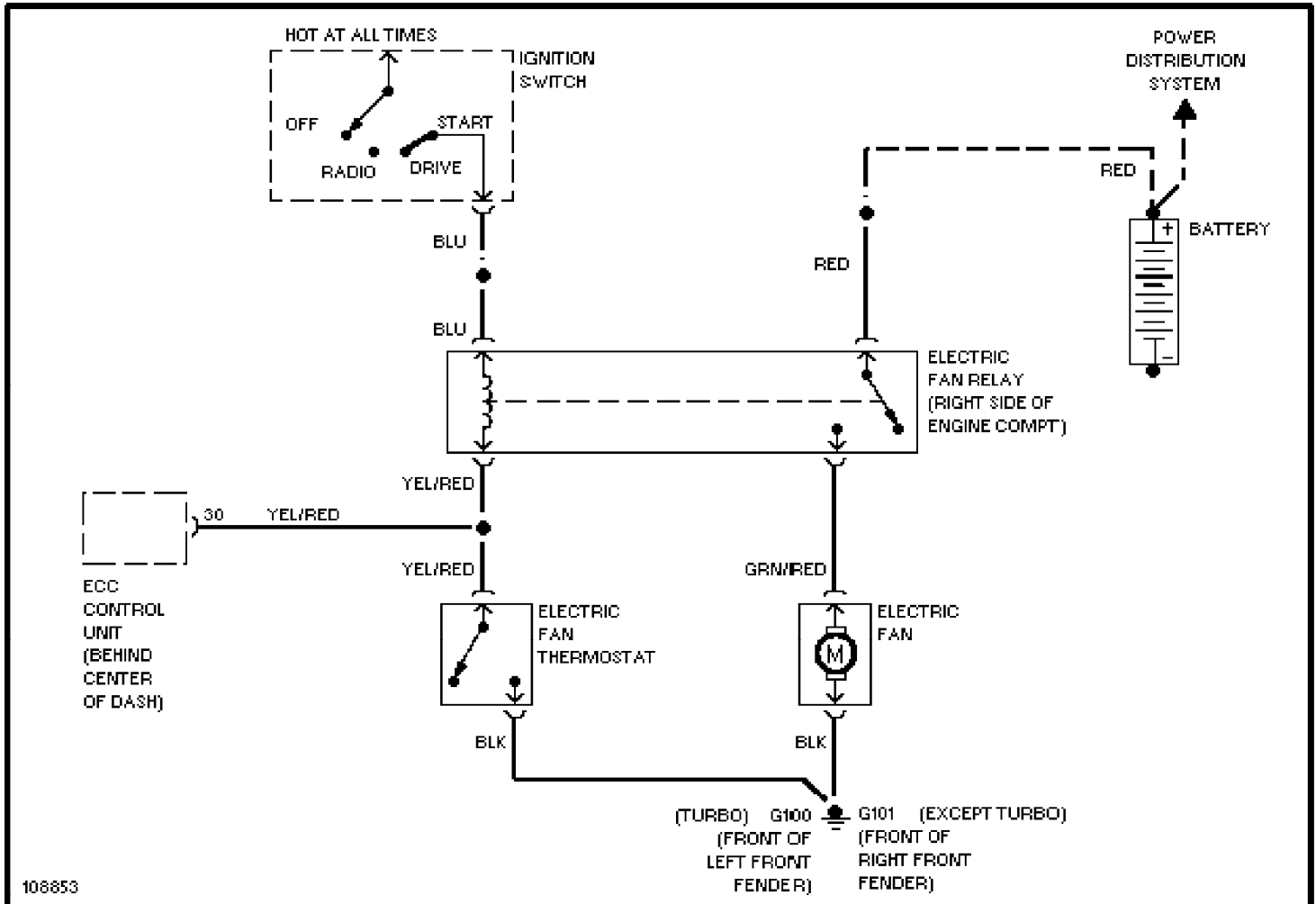

# SYSTEM WIRING DIAGRAMS

## Charging Circuit

1988 Volvo 760

For x

Copyright © 1998 Mitchell Repair Information Company, LLC

Friday, July 23, 2004 08:56PM

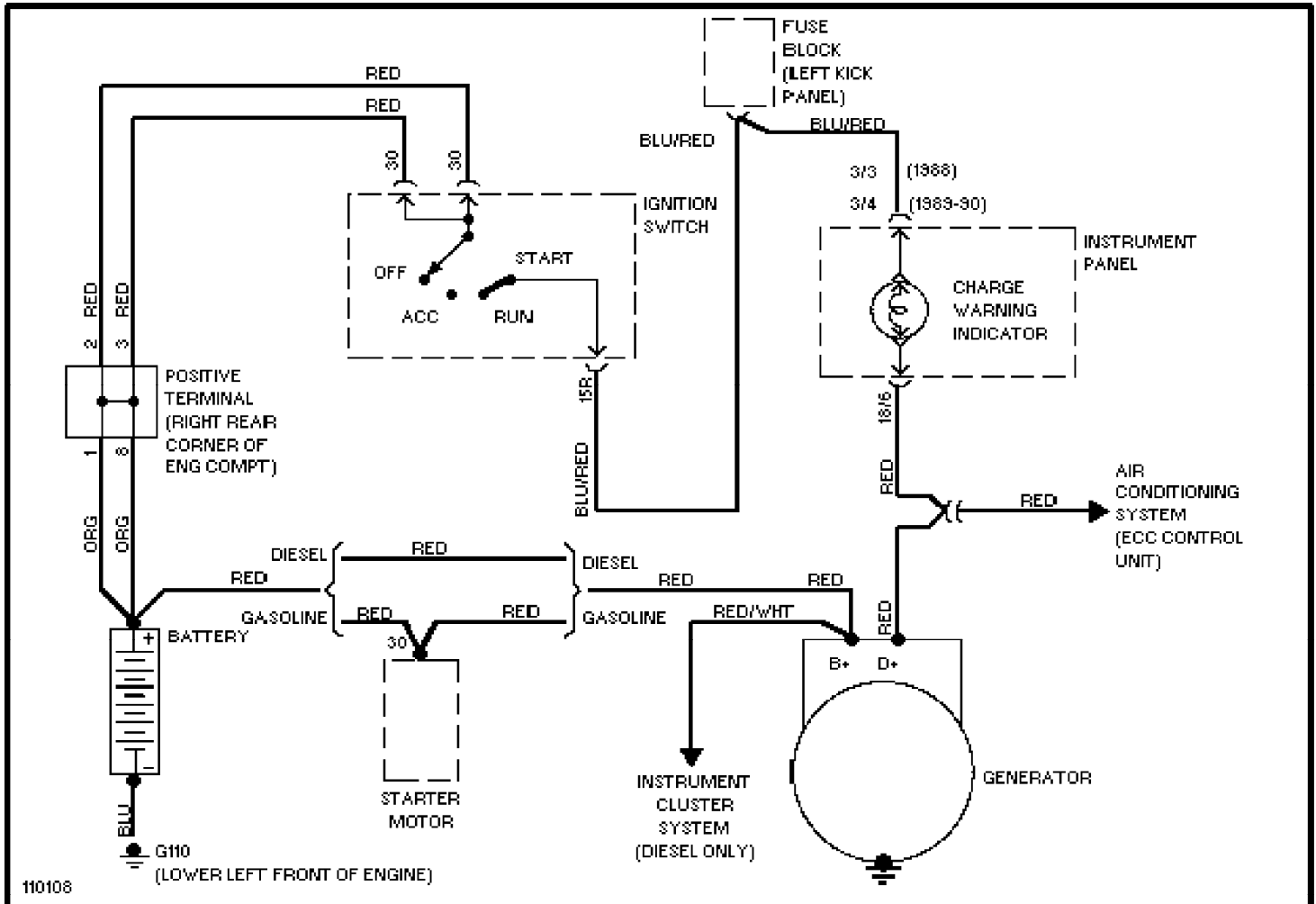

# SYSTEM WIRING DIAGRAMS

## Starting Circuit

1988 Volvo 760

For x

Copyright © 1998 Mitchell Repair Information Company, LLC

Friday, July 23, 2004 08:56PM

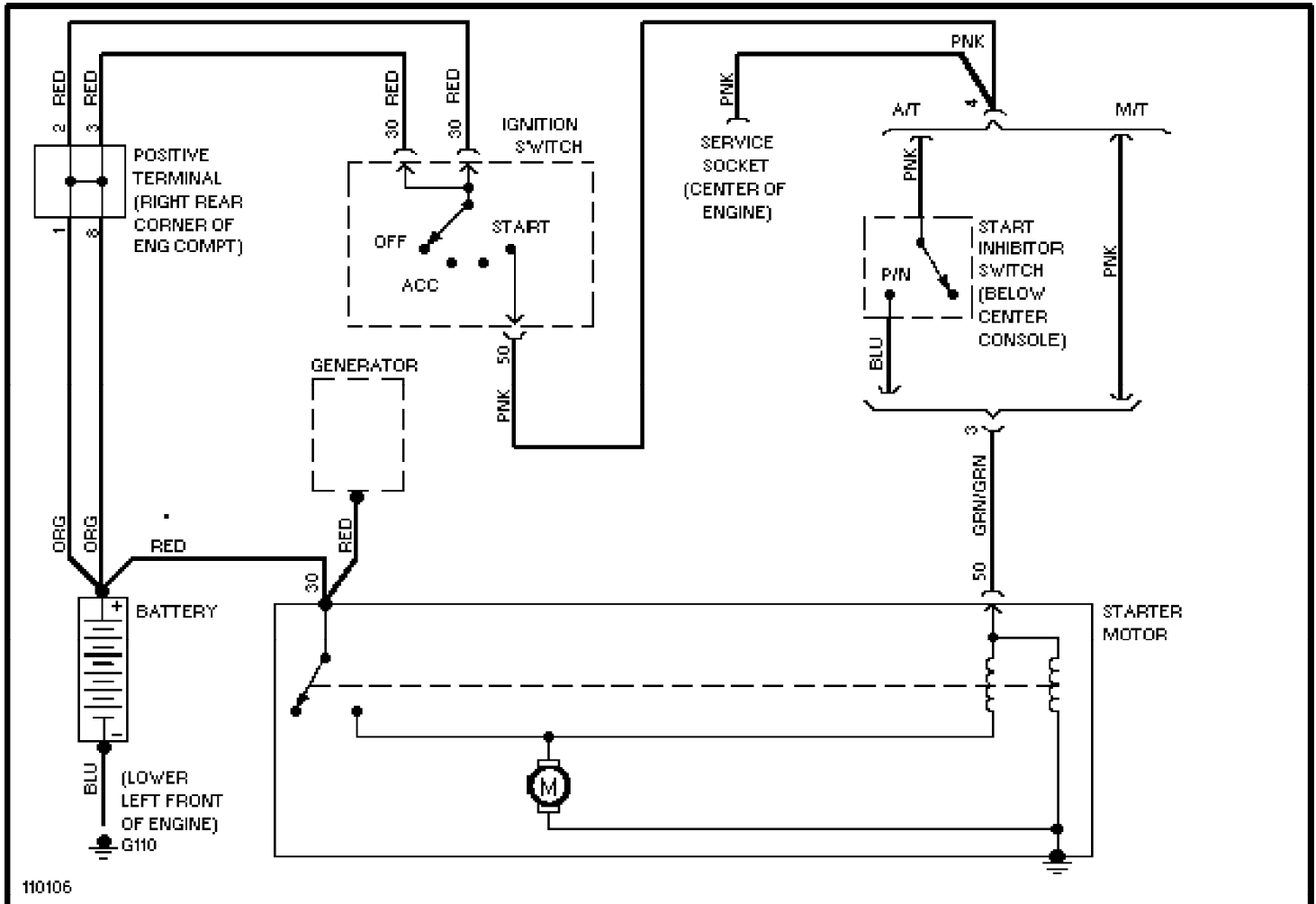

# SYSTEM WIRING DIAGRAMS

## Front Wiper/Washer Circuit

1988 Volvo 760

For x

Copyright © 1998 Mitchell Repair Information Company, LLC

Friday, July 23, 2004 08:56PM

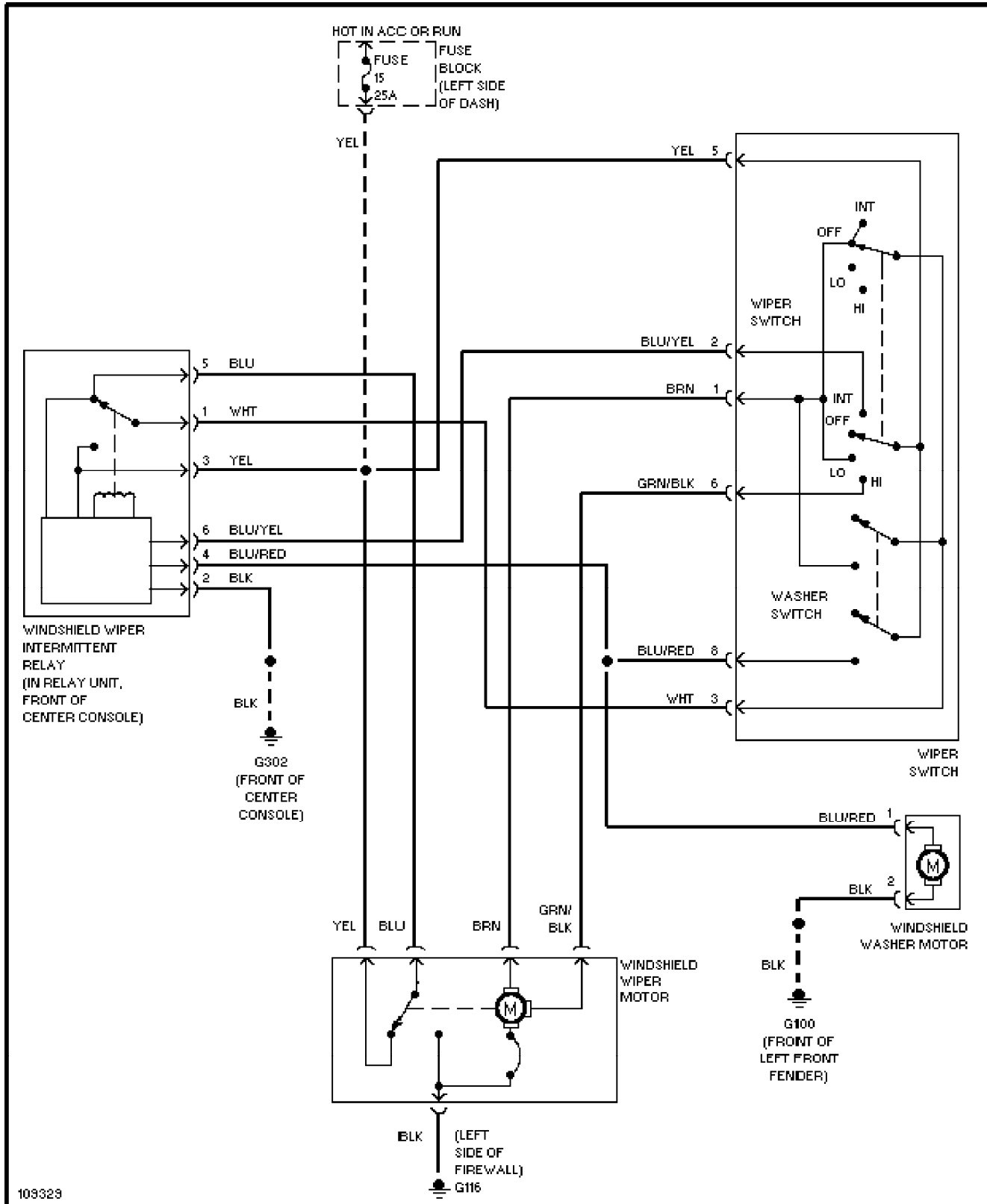

# SYSTEM WIRING DIAGRAMS

## Rear Wiper/Washer Circuit

1988 Volvo 760

For x

Copyright © 1998 Mitchell Repair Information Company, LLC

Friday, July 23, 2004 08:56PM

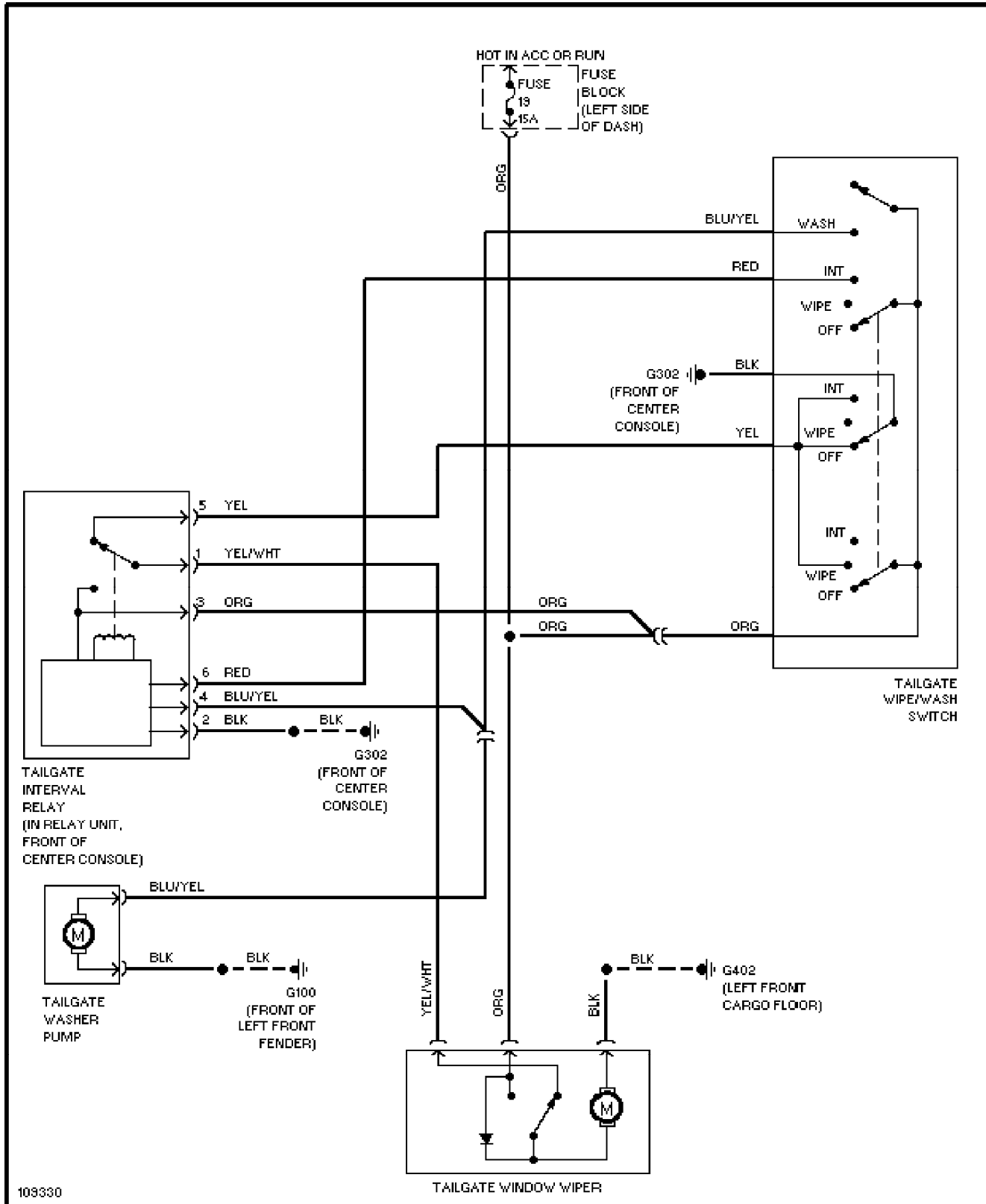

# SYSTEM WIRING DIAGRAMS

## Defogger Circuit, W/O Heated Mirrors

1988 Volvo 760

For x

Copyright © 1998 Mitchell Repair Information Company, LLC

Friday, July 23, 2004 08:55PM

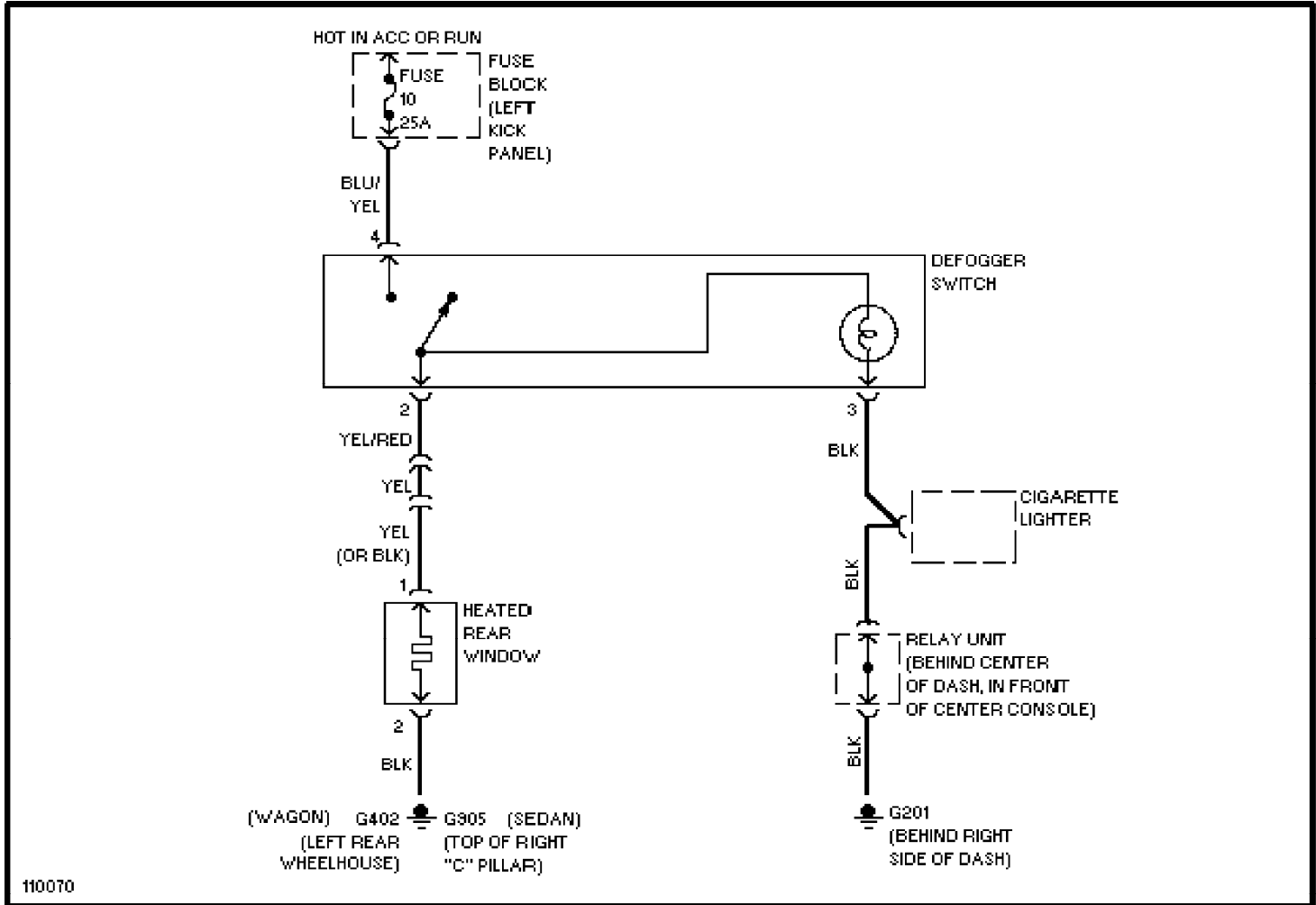

# SYSTEM WIRING DIAGRAMS

## Rear Defogger & Heated Mirrors Circuit

1988 Volvo 760

For x

Copyright © 1998 Mitchell Repair Information Company, LLC

Friday, July 23, 2004 08:56PM

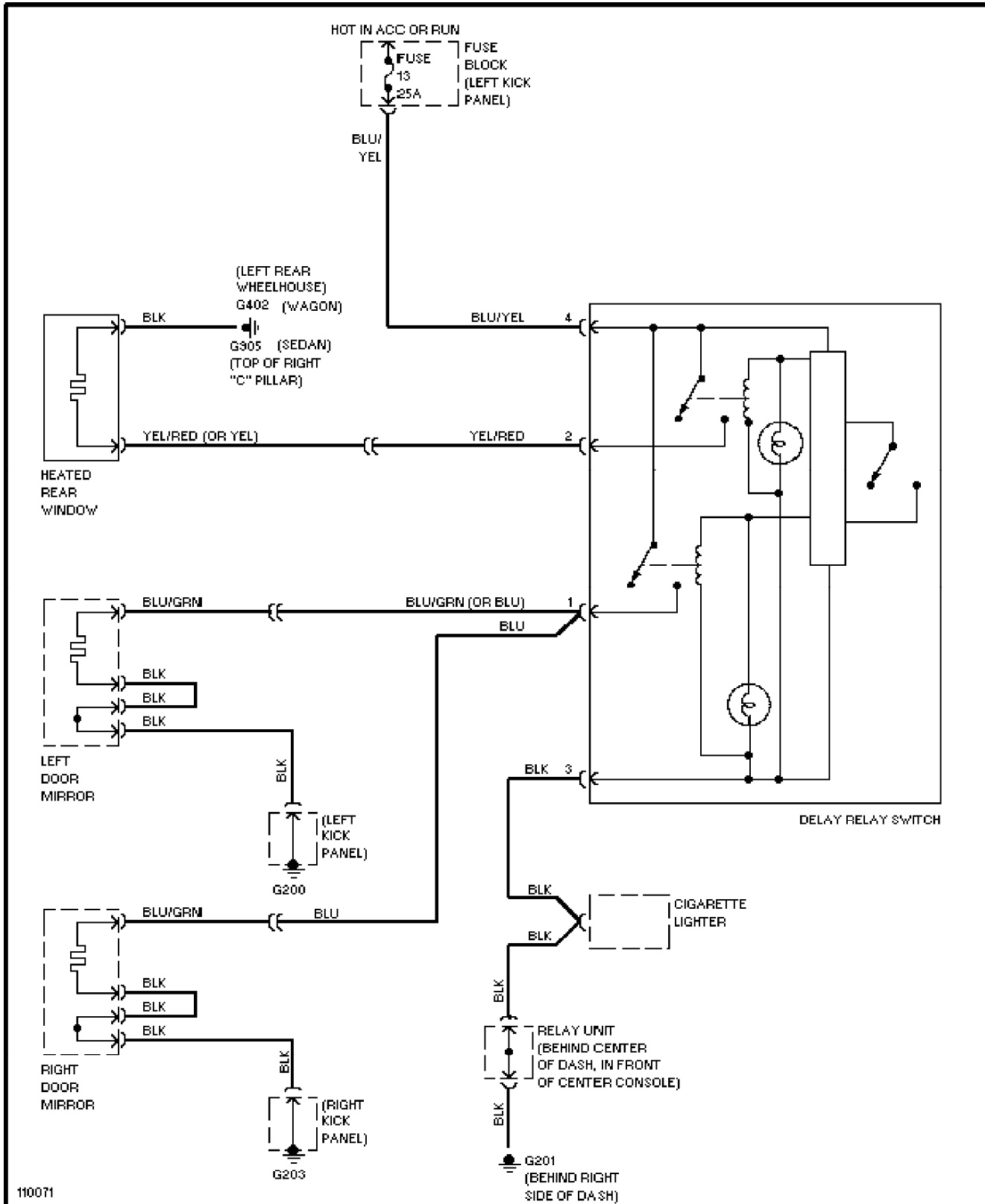

# SYSTEM WIRING DIAGRAMS

## Horn Circuit

1988 Volvo 760

For x

Copyright © 1998 Mitchell Repair Information Company, LLC

Friday, July 23, 2004 08:56PM

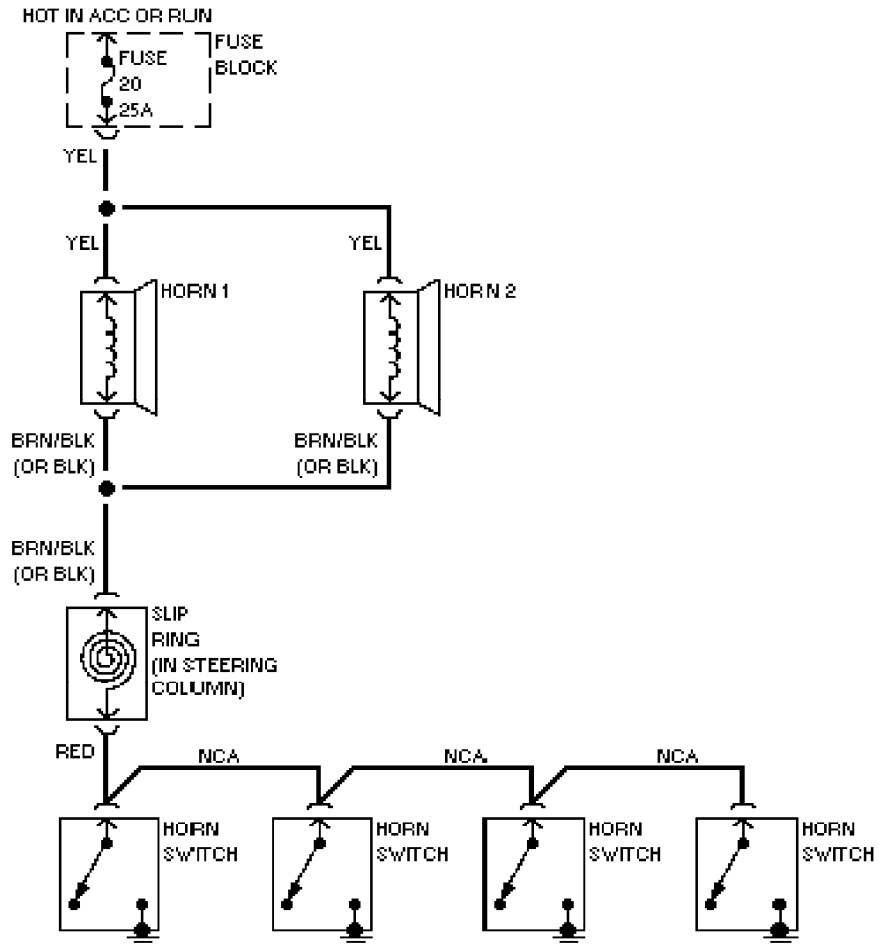

109803



# SYSTEM WIRING DIAGRAMS

## Power Antenna Circuit

1988 Volvo 760

For x

Copyright © 1998 Mitchell Repair Information Company, LLC

Friday, July 23, 2004 08:56PM

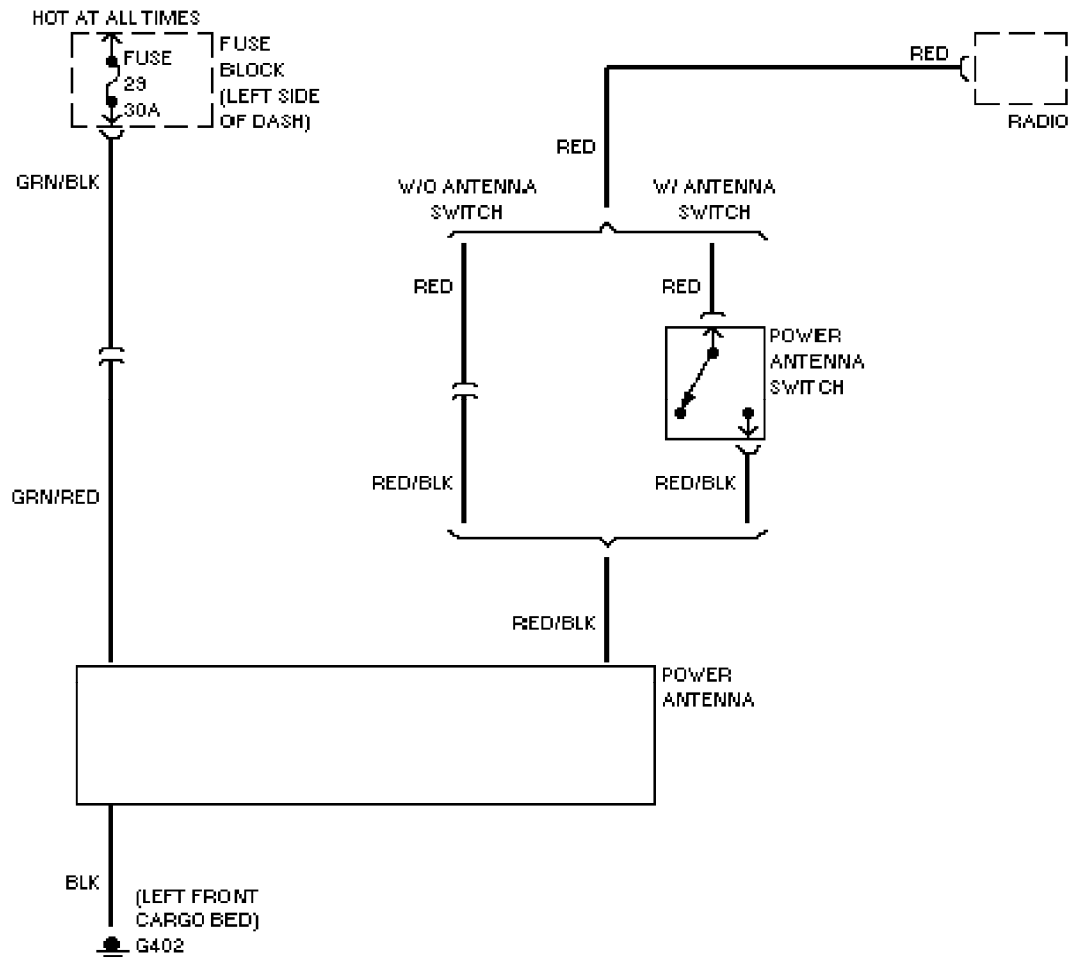

# SYSTEM WIRING DIAGRAMS

## Power Door Lock Circuit

1988 Volvo 760

For x

Copyright © 1998 Mitchell Repair Information Company, LLC

Friday, July 23, 2004 08:56PM

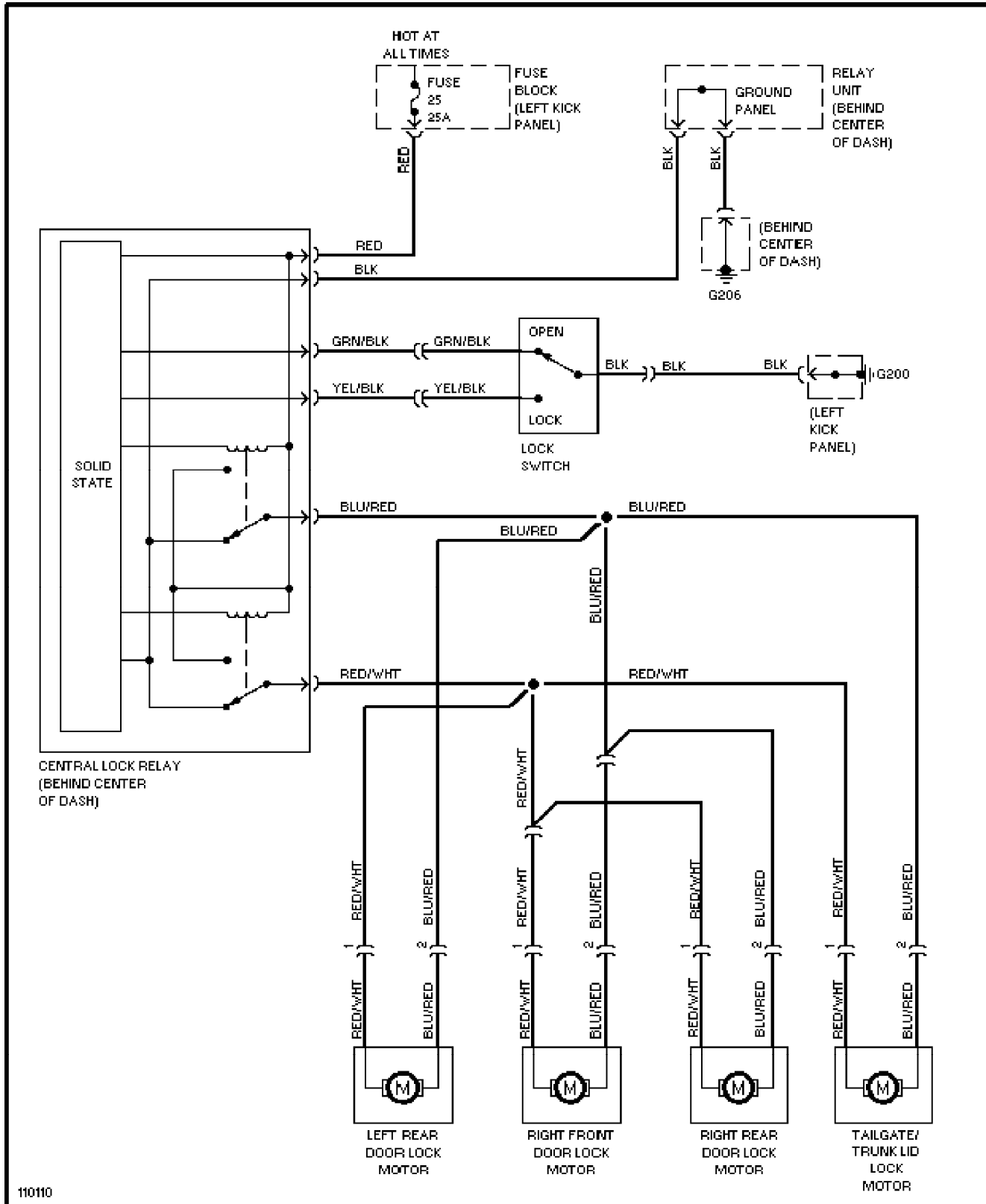

# SYSTEM WIRING DIAGRAMS

## Power Mirror Circuit

1988 Volvo 760

For x

Copyright © 1998 Mitchell Repair Information Company, LLC

Friday, July 23, 2004 08:56PM

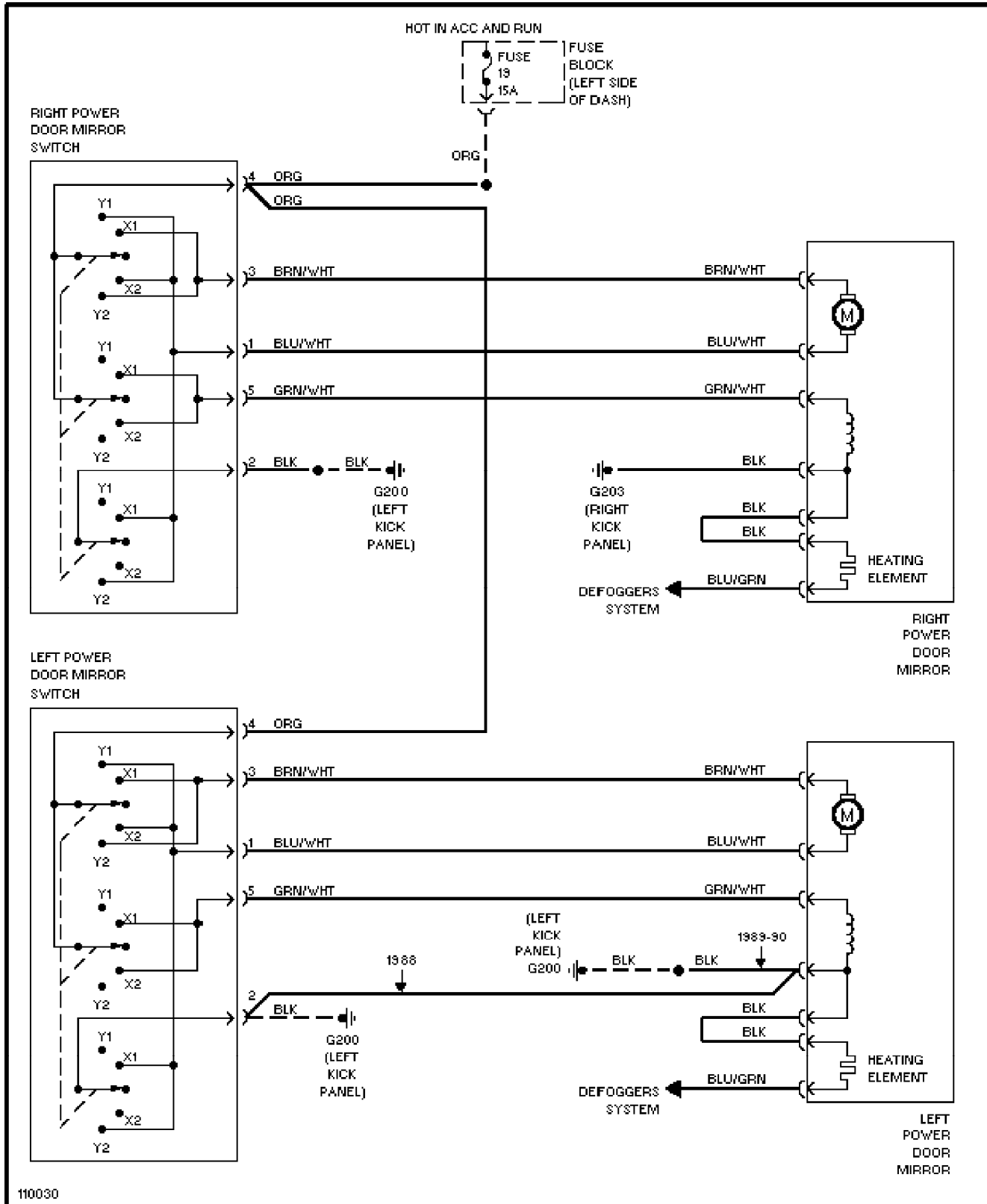



# SYSTEM WIRING DIAGRAMS

## Power Seat Circuit

1988 Volvo 760

For x

Copyright © 1998 Mitchell Repair Information Company, LLC

Friday, July 23, 2004 08:56PM

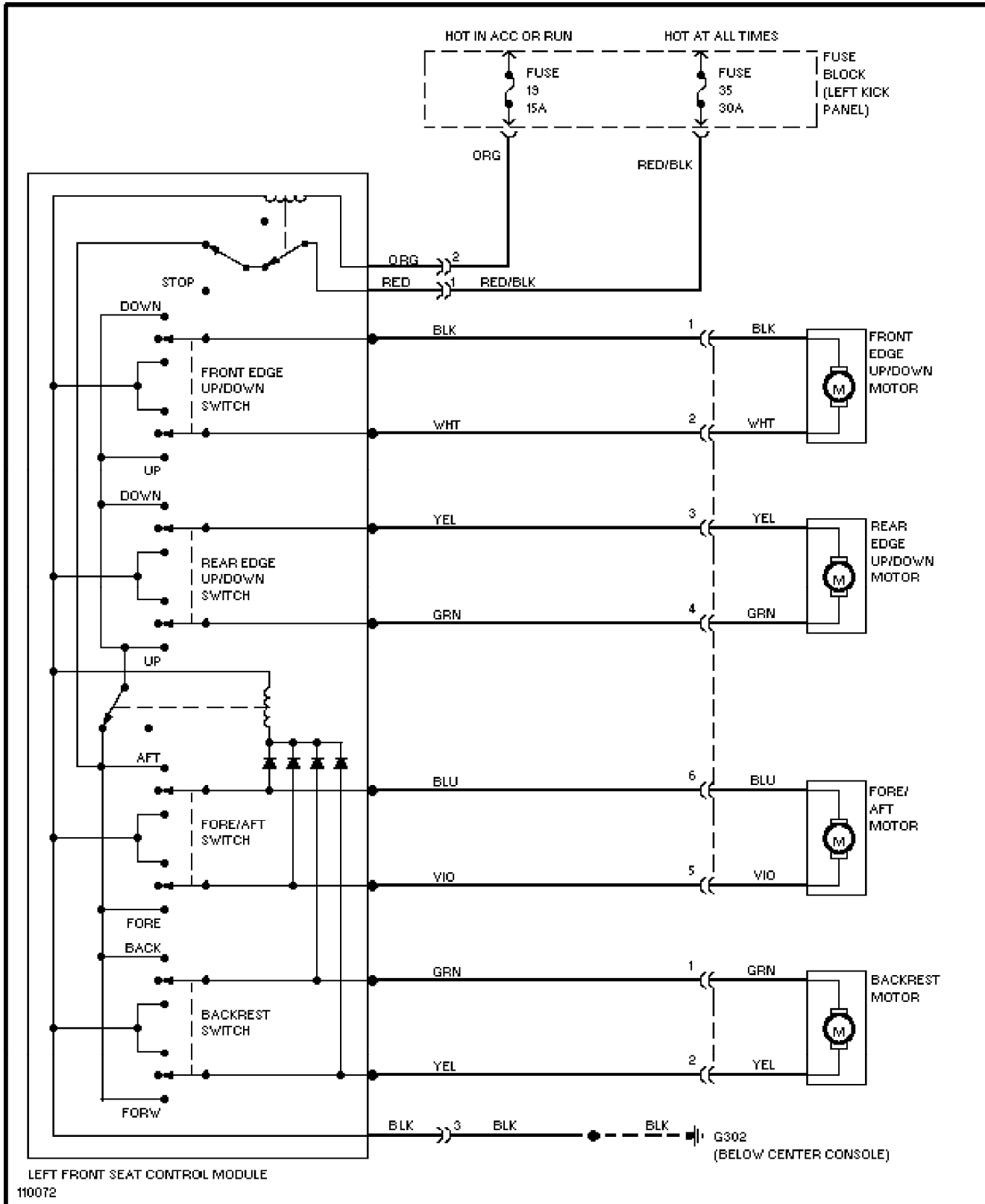

# SYSTEM WIRING DIAGRAMS

## Power Window Circuit

1988 Volvo 760

For x

Copyright © 1998 Mitchell Repair Information Company, LLC

Friday, July 23, 2004 08:56PM

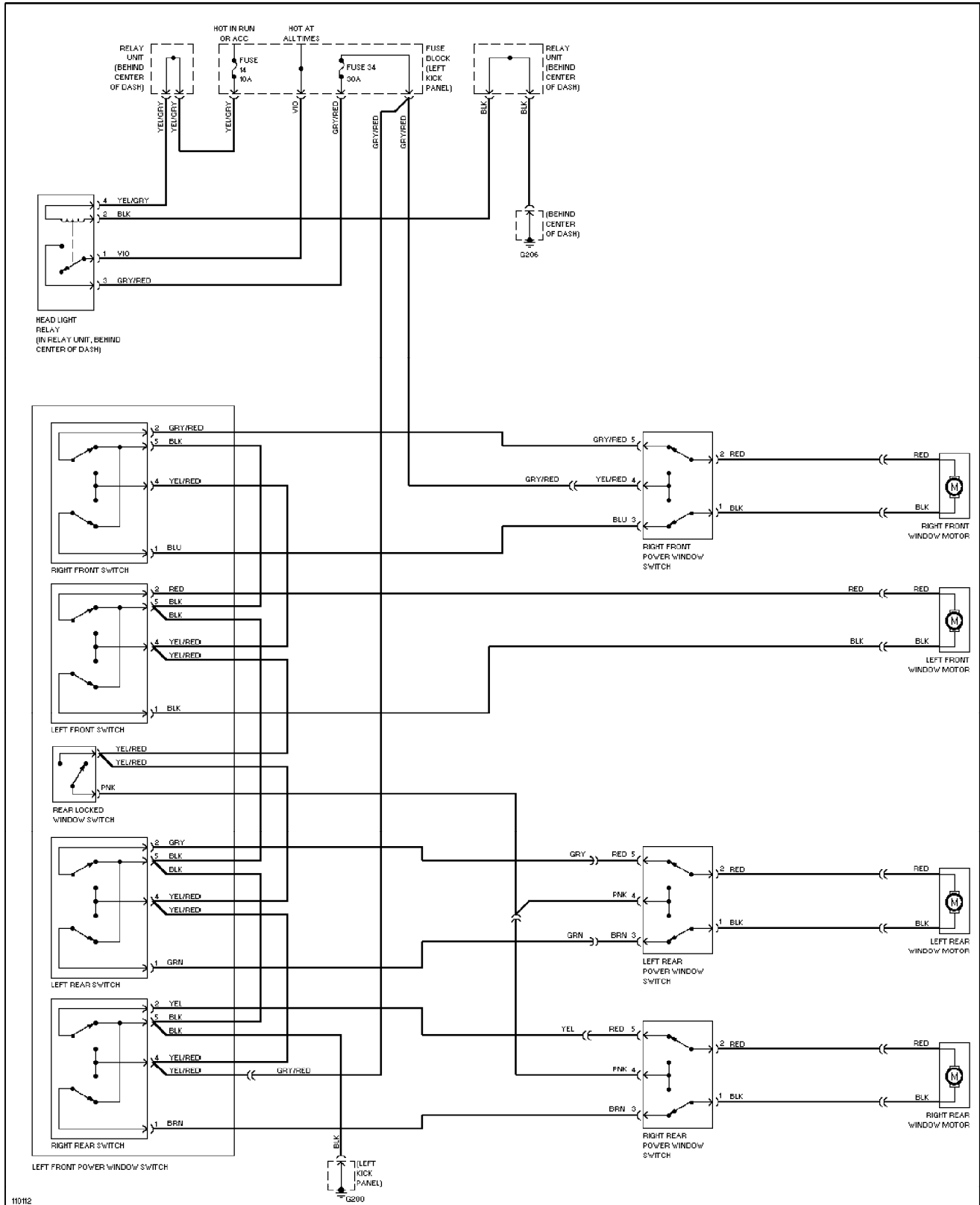

# SYSTEM WIRING DIAGRAMS

## Radio Circuits

1988 Volvo 760

For x

Copyright © 1998 Mitchell Repair Information Company, LLC

Friday, July 23, 2004 08:56PM

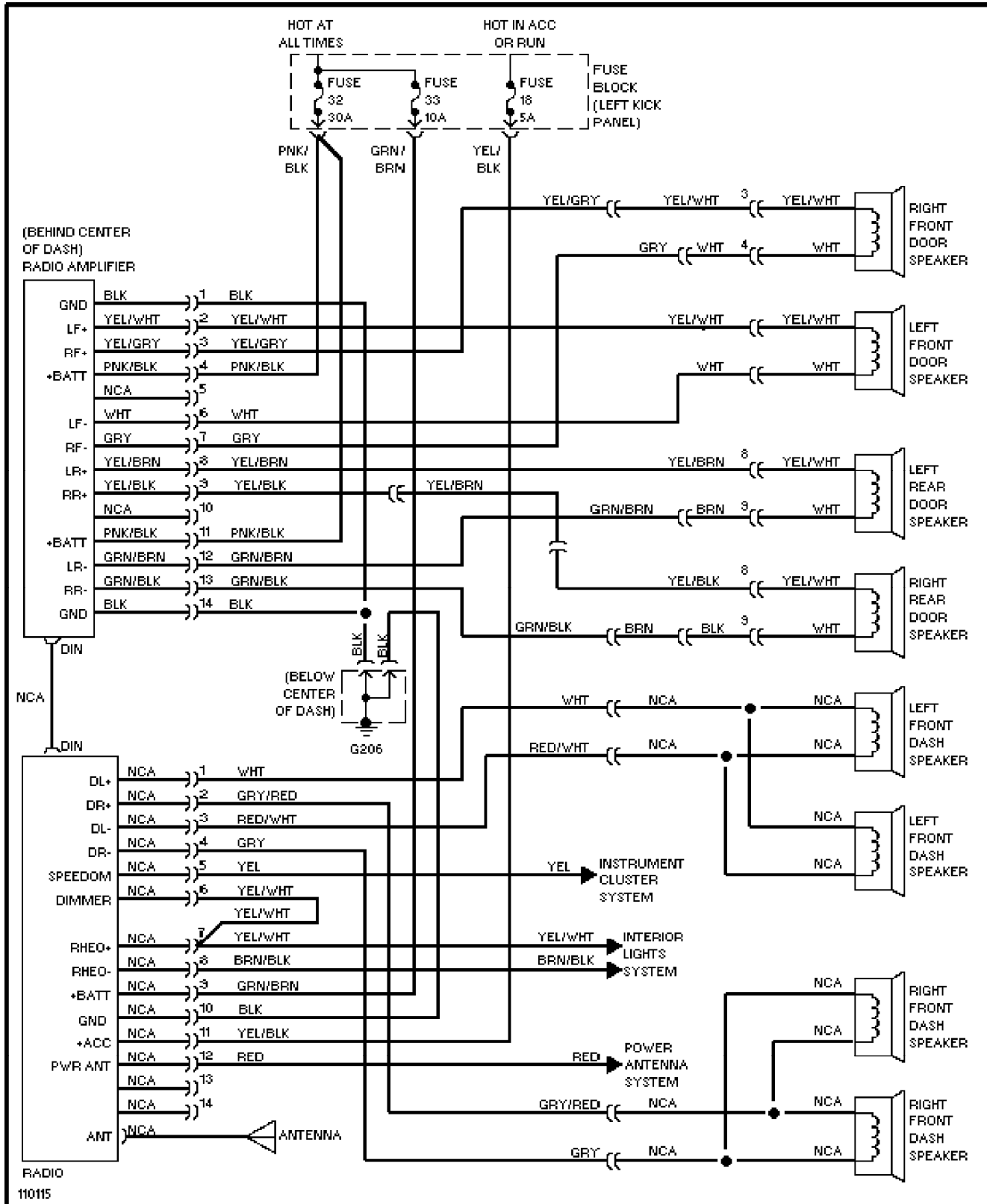





# WIRING DIAGRAMS

## Fig. 8: Instrument Panel

1988 Volvo 760

For x

Copyright © 1998 Mitchell Repair Information Company, LLC

Friday, July 23, 2004 08:57PM

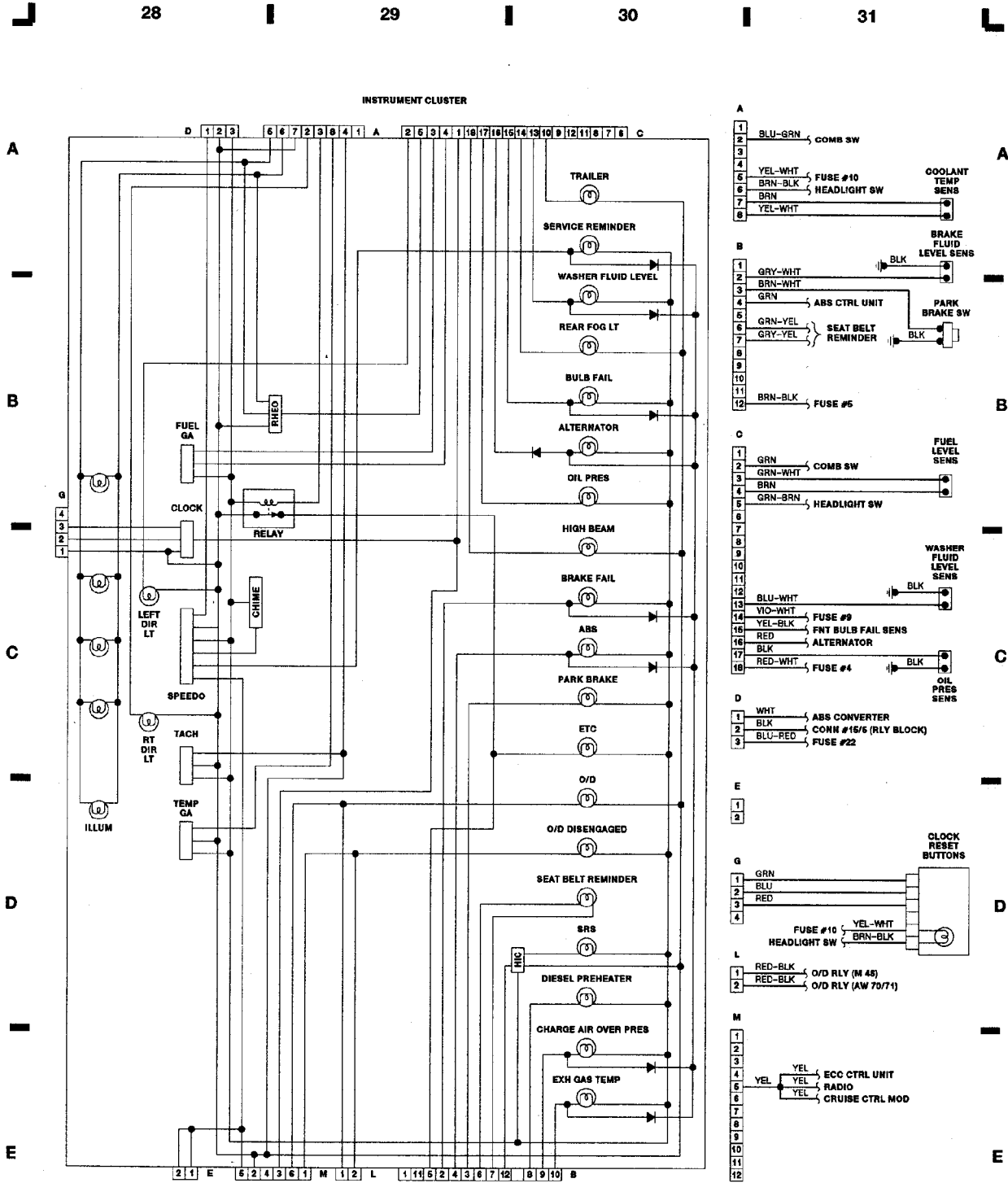

# WIRING DIAGRAMS

## Fig. 9: Passenger Compartment

### 1988 Volvo 760

For x  
 Copyright © 1998 Mitchell Repair Information Company, LLC  
 Friday, July 23, 2004 08:58PM

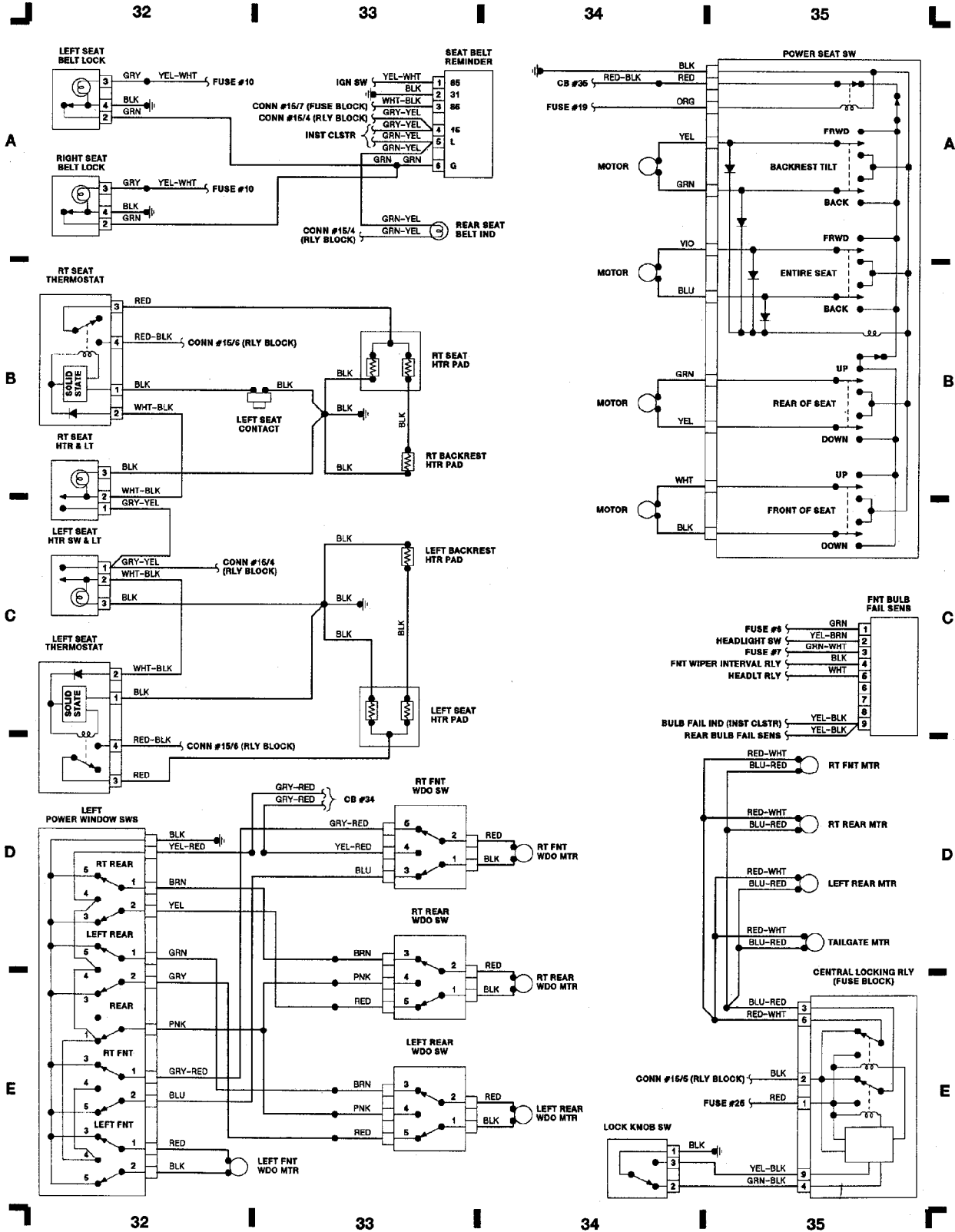

# WIRING DIAGRAMS

## Fig. 10: Passenger Compartment (Cont.) & Taillights

1988 Volvo 760  
For x  
Copyright © 1998 Mitchell Repair Information Company, LLC  
Friday, July 23, 2004 08:58PM

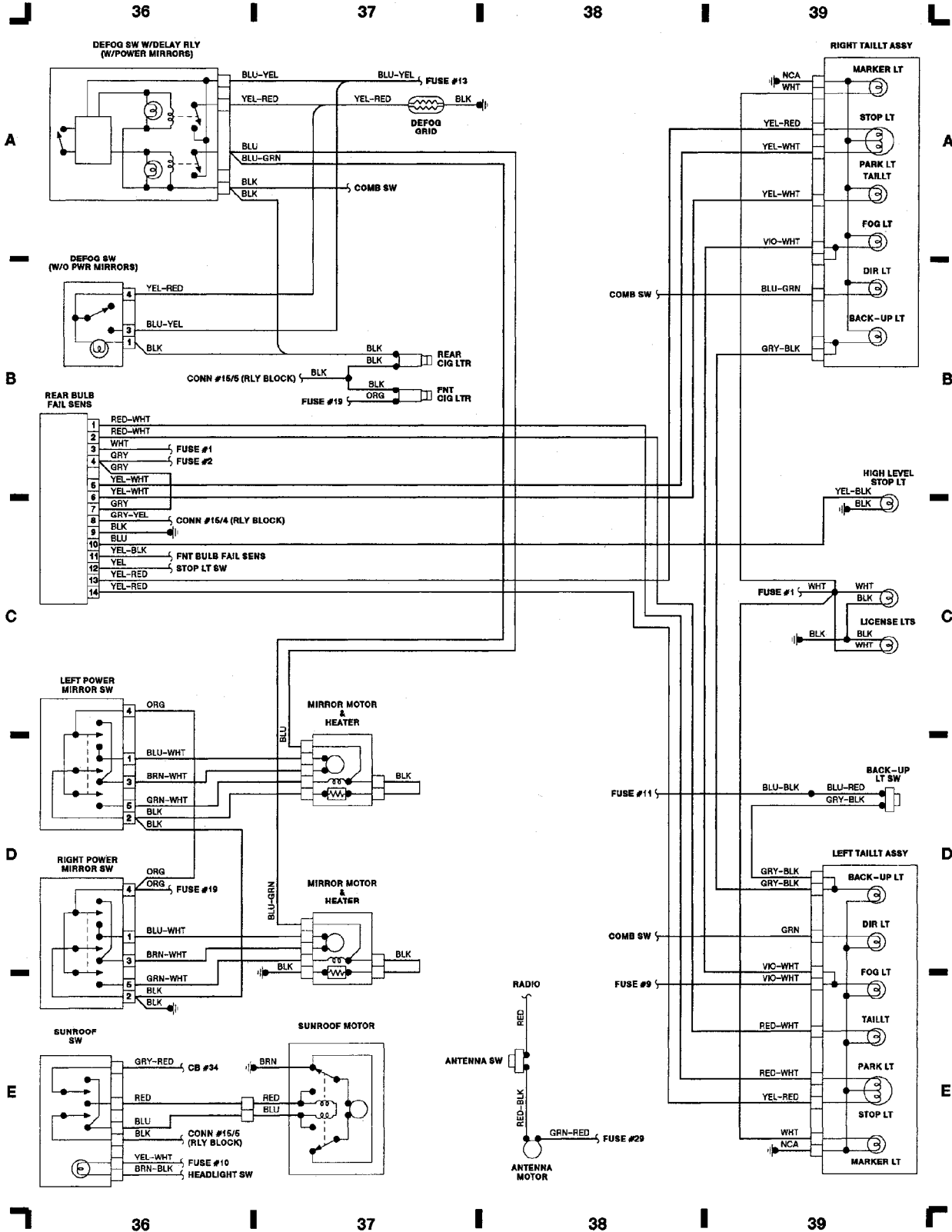

# WIRING DIAGRAMS

## Fig. 1: Engine Compartment & Headlights

1988 Volvo 760

For x

Copyright © 1998 Mitchell Repair Information Company, LLC

Friday, July 23, 2004 08:57PM

### COMPONENT LOCATOR:

ABS CTRL SYSTEM	.....	A-C 24-27
ALTERNATOR	.....	C 3
ANTENNA MTR & SW	.....	E 38
ASHTRAY LIGHT (FNT & REAR)	.....	E 12
BACK-UP LIGHT SWITCH	.....	D 39
BATTERY	.....	A 2
BRAKE FLUID LEVEL SENS	.....	A 31
CENTRAL LOCKING RELAY	.....	D-E 34-35
CIG LTRS	.....	B 37
CIG LTR LIGHT	.....	E 12
CLOCK RESET BUTTONS	.....	D 31
COMB SWITCH	.....	A-B 20
CONN #15/2	.....	A 17
CONN #15/3	.....	A 14
CONN #15/4	.....	A 18
CONN #15/5	.....	B 17-18
CONN #15/6	.....	B 16-17
CONN #15/7	.....	A-B 14
COOLANT TEMP SENS	.....	A 31
COOLING FAN SYSTEM	.....	C D 1-2
CRUISE CTRL SYSTEM	.....	C-D 24-25
DEFOG SYSTEM	.....	A-B 36
DOOR SWITCHES	.....	D-E 24
ELECTRONIC CLIMATE CONTROL (ECC)	.....	C-E 16-19
FOG LIGHT RELAY	.....	B-C 20
FOG LIGHT SWITCH	.....	C-D 20
FRONT BULB FAIL SENSOR	.....	C 35
FUEL LEVEL SENSOR	.....	D 20
FUEL PUMP (MAIN)	.....	C 6, C 10
FUEL PUMP (TANK)	.....	C 7, B 10
FUEL PUMP RELAY	.....	B 7, B 11
FUSE BLOCK	.....	A-E 13-14
GEAR SEL SWITCH LIGHT	.....	E 12
GLOVE BOX LIGHT & SWITCH	.....	D-E 20
HEADLIGHT RELAY	.....	B-C 23
HEADLIGHT SWITCH	.....	A-B 23
HEATER BLOWER MOTOR	.....	D 16
IGNITION COIL	.....	C 4, C 8
IGNITION SWITCH	.....	C 16
IGNITION SYSTEM CONTROL UNIT	.....	D-E 4, D-E 8
INSTRUMENT CLUSTER	.....	A-E 28-30
INTERIOR LIGHTS	.....	D-E 25-27
JUNCTION BLOCK	.....	A-B 23
LAMBOA-SOND	.....	C 7, C 11
LH JETRONIC CTRL UNIT	.....	A 4, A 8
OIL PRESSURE SWITCH	.....	C 31
OVERDRIVE SYSTEM	.....	E 3
PARK BRAKE SWITCH	.....	B 31
POWER MIRROR SYSTEM	.....	C-D 36-37
POWER SEAT SYSTEM	.....	A-C 35
POWER WINDOW RELAY	.....	D 20
POWER WINDOW SYSTEM	.....	D-E 32-34
REAR BULB FAIL SENSOR	.....	B-C 36
REAR WIPER INTERVAL RELAY	.....	D-E 21
REAR WIPER MOTOR	.....	E 25
REAR WIPER/WASHER SWITCH	.....	D-E 23
RELAY BLOCK	.....	A-B 17-18
SEAT BELT LOCKS	.....	A 32
SEAT BELT REMINDER	.....	A 33-34
SEAT HEATER SWITCH LIGHT	.....	E 12
SEAT HEATER SYSTEM	.....	B-D 32-33
SRS SYSTEM	.....	C 26-27
STARTER MOTOR	.....	B-C 3
STOP LIGHT SWITCH	.....	D 24
SUNROOF SYSTEM	.....	E 36-37
TEST CONN	.....	B 7, B 11
VANITY MIRROR LIGHTS	.....	E 20
WASHER FLUID LEVEL SENS	.....	C 31
WASHER MOTOR	.....	C-D 3
WIPER INTERVAL RELAY	.....	C-D 23

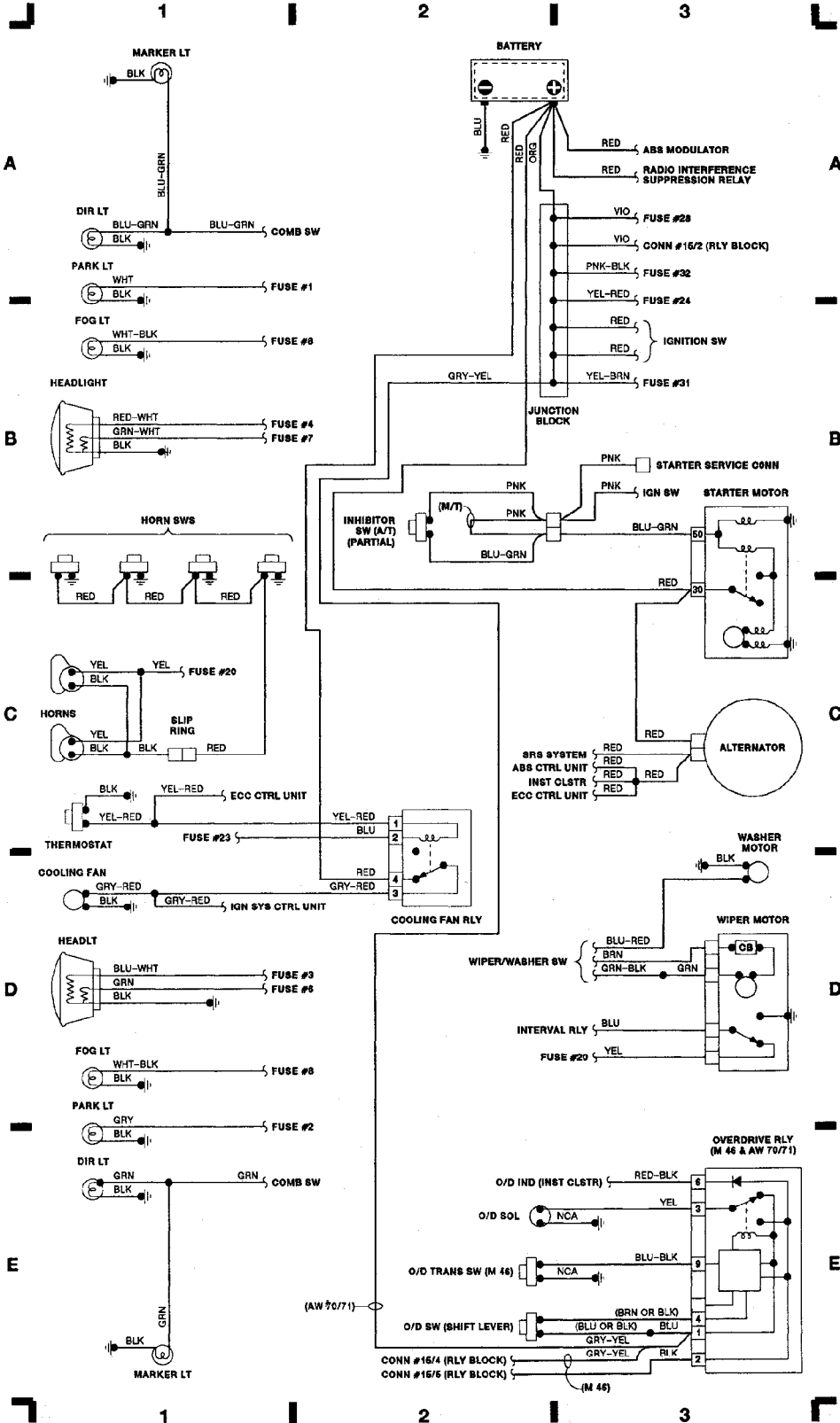

# WIRING DIAGRAMS

## Fig. 2: Computer Engine Control (2.3L Turbo)

1988 Volvo 760  
For x  
Copyright © 1998 Mitchell Repair Information Company, LLC  
Friday, July 23, 2004 08:57PM

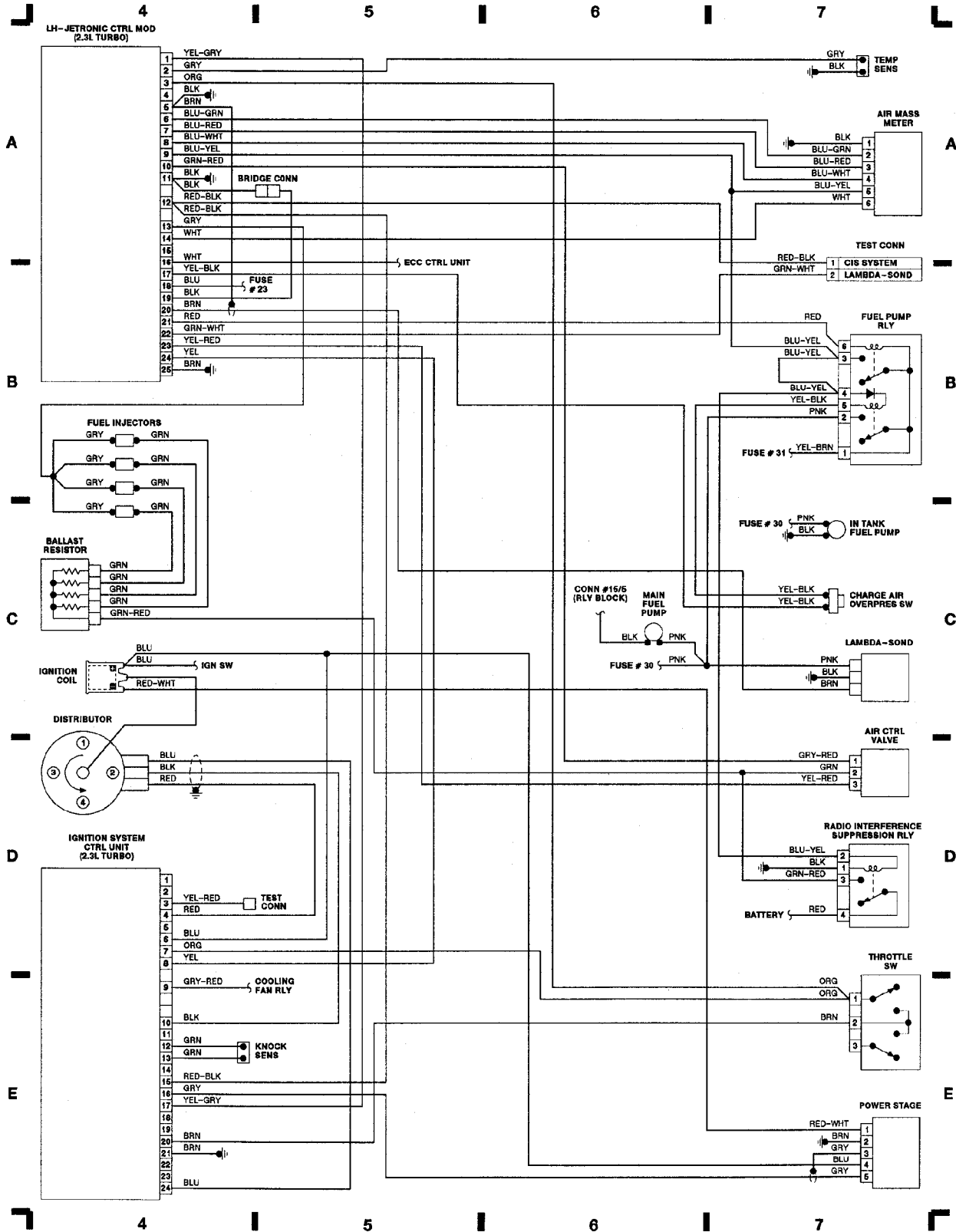

# WIRING DIAGRAMS

## Fig. 3: Computer Engine Control (2.8L V6)

1988 Volvo 760  
For x  
Copyright © 1998 Mitchell Repair Information Company, LLC  
Friday, July 23, 2004 08:57PM

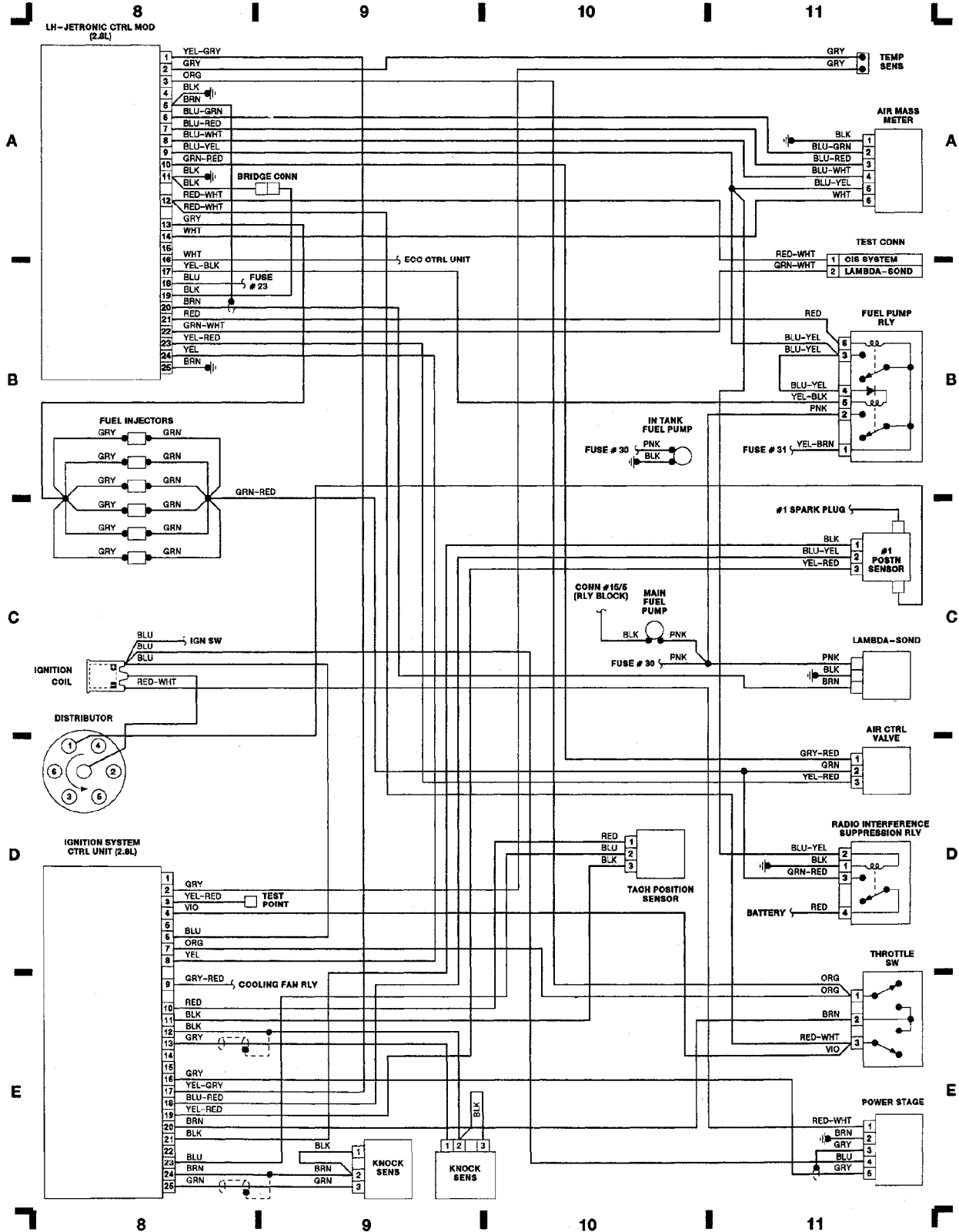



# WIRING DIAGRAMS

## Fig. 5: Relay Panel & A/C & Heating System

1988 Volvo 760  
For x  
Copyright © 1998 Mitchell Repair Information Company, LLC  
Friday, July 23, 2004 08:57PM

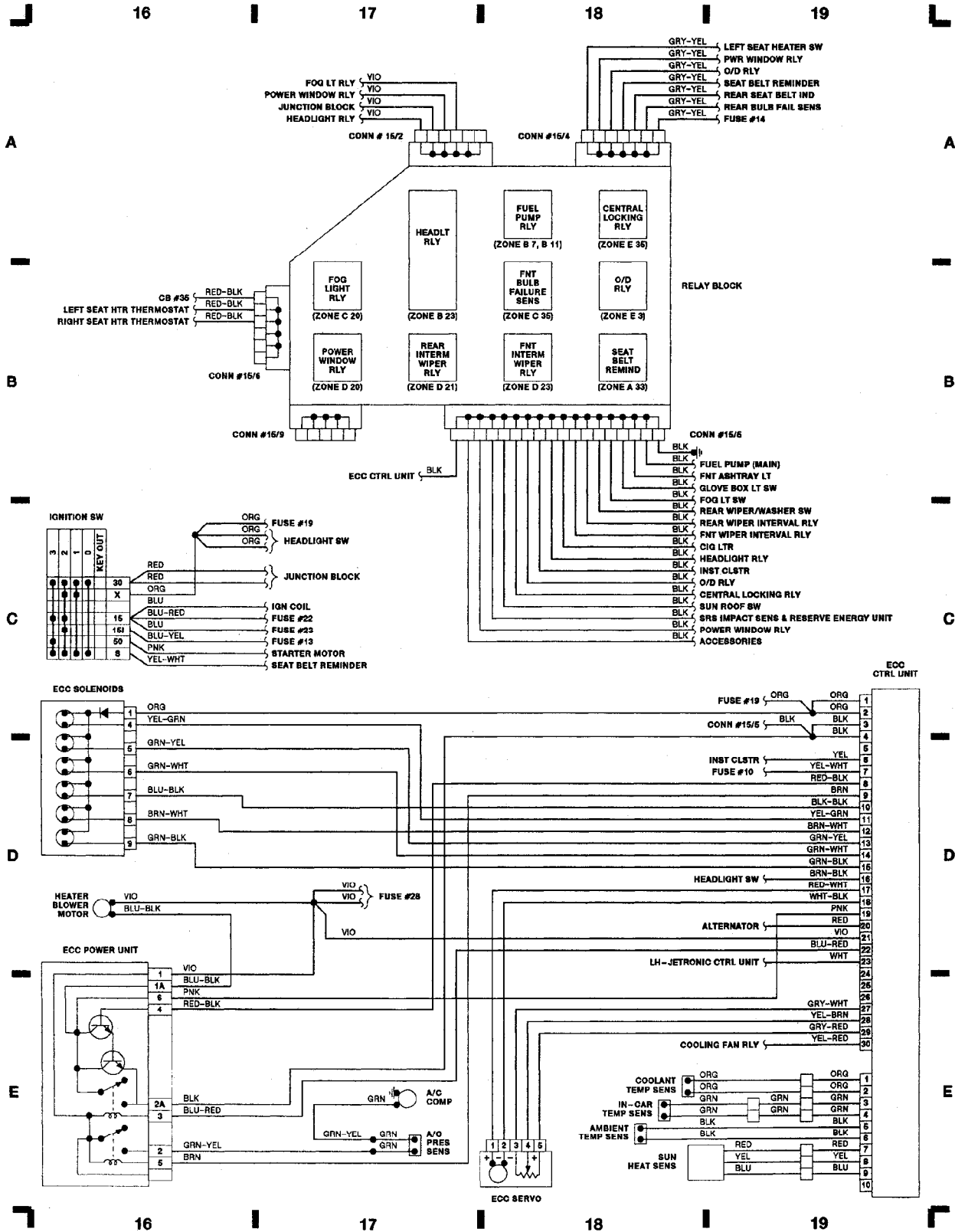



# WIRING DIAGRAMS

## Fig. 6: Steering Column Switches & Instrument Panel Switches

1988 Volvo 760

For x

Copyright © 1998 Mitchell Repair Information Company, LLC

Friday, July 23, 2004 08:57PM

