

P R E S S



I N F O R M A T I O N

VOLVO





VOLVO CAR B.V.

PRESS MATERIAL

GENEVA 1988

1. THREE ACTION MODELS HERALD THE ARRIVAL OF THE MILLIONTH VOLVO 300
2. MILLIONTH VOLVO 300 MERELY ANOTHER MILESTONE ALONG THE ROAD
3. VOLVO 480 RANGE
4. VOLVO CAR B.V. CLIMBS TO PROFIT OF NLG 20 MILLION

Marketing Public Relations
P.O. Box 1015
5700 MC Helmond
The Netherlands
Phone (0)4920 - 66111
Telex 51982
Telefax (0)4920 - 36995

Press Information

THREE ACTION MODELS HERALD THE ARRIVAL OF THE MILLIONTH VOLVO 300

Three action models, endowed with an extra attractive and high-level equipment specification, will add lustre to the production of the millionth car in the Volvo 300 Series in March. In order to underline and retain the exclusive character of these cars, they will be built in a very limited number.

LUXURY

Star of the action models is the 'Millionaire'. This model, based on the 340 GLE 4-door sedan, is representative of what Volvo Car B.V. has to offer in the way of luxury, ride comfort and quality.

Depending upon the market variant, an engraved plate will be mounted on the dashboard showing the serial number, the number of cars built in this limited series and the date of manufacture.

While the standard specification provides for a 1.7-litre engine, this may vary from country to country. The exterior colour is smoke silver metallic with a special silver-grey striping. Equipment includes colour-matched bumpers and petrol filler cap, 13" alloy wheels, wide body side protection mouldings, padded head restraints at front and rear, a three-band radio/cassette unit with digital readout, two loudspeakers (one in each front door), central locking, electrically operated front door windows, a rev counter and oil pressure and temperature gauges.

REDLINE FAMILY

The other two action models have been named 'Redline' and will be available in two variants: Redline Family and Redline Sporty. The family version - based on the 340 DL 5-door hatchback - will have a 1.7-litre engine in the standard specification, although here again this may vary from country to country. Our choice of exterior colour is blue metallic but other colours are available upon request (graphite, black, smoke silver - all metallic). Equipment includes tinted glass, a special red striping, black bumpers with bright decor moulding, special wheel covers, wide body side protection mouldings, padded head restraints, an extended tunnel console and a three-band radio/cassette unit with digital readout and two loudspeakers (one in each front door).

REDLINE SPORTY

The third action model is the Redline Sporty, based on the 340 GL 5-door hatchback. Here too, the engine type may vary from country to country but in the standard specification a 1.7-litre engine is fitted. Black metallic is our proposal for the exterior colour, but graphite metallic and smoke silver metallic are also possible. The standard equipment package includes a special Redline decal, black grille, rear spoiler, black bumpers with red decor moulding, large wheel covers, wide body side protection mouldings, grey GLT seat covers with red piping, padded head restraints, a three-band radio/cassette unit with digital readout, two loudspeakers (one in each front door), central locking and a rev counter.

MILLIONTH VOLVO 300 MERELY ANOTHER MILESTONE ALONG THE ROAD

On 19 February 1976 the 'best kept secret' of the Volvo organization was revealed. For many, the introduction of the Dutch developed and Dutch manufactured Volvo 343 came as a complete surprise. On 8 March 1988 the millionth variant in the 300 series will drive off the assembly line at Volvo's Born plant in the South of Holland. And that is equally surprising.

The fact that after 12 years in production, a car is still so popular that it will continue to be manufactured into the 'nineties.

Individuality, consistent innovation and expansion of the range undoubtedly lie at the root of this ongoing popularity. Each year has seen the introduction of product improvements, fine-tuning of the production process and a greater variation in the model line-up.

ACTION MODEL

The Volvo 'Millionaire', exhibited here at the international Geneva Motor Show, symbolizes the road travelled by the Volvo 300. This special action model, of which only a limited number will be built, exemplifies what has been achieved in the Volvo 300 Series in terms of luxury, ride comfort and quality. The possible combinations of body styles, engines, transmissions, equipment and trim levels, colours, upholstery choice, options and market variants is at the present time virtually inexhaustible. For the nearly sixty countries where the 300 Series is sold, Volvo manufactures on a customer oriented basis - which amounts to making what the consumer demands. In practice this means that a selection of more than 80,000 variants is actually manufactured.

INTERNATIONAL BOW

It is not without reason that this 'millionaire' is on the Volvo stand at Geneva. The first Volvo 343 made its international bow here in March 1976, introducing a hatchback which represented a totally new concept in terms of styling. The aerodynamics of this styling, for example, helped to keep the rear window clear when driving in bad weather. Another outstanding characteristic was the roadholding - the result of a perfect front/rear weight distribution. By installing the engine at the front and the cluck/gearbox/final drive/differential at the rear (transaxle design) in combination with a de Dion rear axle, it was possible to achieve a low unsprung weight for this rear wheel drive car. Other praised features included the comfortable interior, the complete equipment package, the large, variable load-carrying capacity and the high levels of active and passive safety.

GREAT LEAP FORWARD

After this positive reception, the many possibilities offered by this strong concept were developed further. In 1979 the 5-door variant was introduced as the Volvo 345. A year earlier a manual four-speed gearbox variant joined the model line-up, alongside the automatic variant (CVT) which, until then, had been the standard transmission in the 300 Series. In 1980 the power choice was expanded with a 2-litre variant, characterized by a high torque over a wide engine speed band. This team mate to the 1.4-litre engine represented a great leap forward - certainly for people looking for caravan pulling power.

INDEPENDENT

In 1981 - when Volvo Car B.V. became financial independent company within the Volvo group - the first step along the road to a new future was the presentation of a different front end on the 300 models. Apart from enhancing the appearance, this facelift also helped to reduce fuel consumption by considerably lowering the drag coefficient of the car. In September 1982 the first 360 GLT came off the assembly line - a car with a fuel injection engine and extra sporty appeal. A year later Volvo Car B.V. introduced the 340/360 Sedan and firmly established a third main model in the range. Top-of-the-line variant became the exclusive 360 GLE.

CLEAN POWER UNITS

In December 1983 there was another cause for celebration when the hundred-thousandth 300 of that year was produced. In 1984 Volvo Car B.V. launched the 340 Diesel, followed a year later by the 340 with a 1.7-litre petrol engine (B 172). In the mean time a manual five-speed overdrive gearbox had become available. With the arrival of the 1.7-litre engine, the 300 Series also underwent a number of external modifications which made it even more up-to-date. Since 1985 the emphasis has been on further enhancing the luxury and comfort; on the introduction of environmentally friendly engines; and on perfecting the smallest details. The 2-litre engines (B 200 range) meet the EEC requirements for clean power units even without a catalytic converter. All the same, they run on all grades of petrol - leaded and unleaded, normal and super. The engines equipped with Pulsair, EGR and catalytic converter systems are models of environmental topicality

INNOVATION

Inspired by the increasing number of export countries in (sub)tropical regions, significant innovative work has been accomplished, as witness inter alia the development of an air-conditioning system which offers optimum performance even in the most extreme conditions. Another result of the company's export efforts was the start (in 1985) of CKD operations. Since the import of road-ready cars in some countries is curtailed by import restrictions, the decision was taken to supply these markets with cars in kit form. In Malaysia these 'Completely Knocked Down' cars are assembled by local labour.

INTERIM RESULT

Of course, history is not an unending string of highlights. History is feast and famine. The 300 Series has also had its setbacks. But without this evolution and refining process, the interim result of 1,000,000 Volvo 340/360's - which includes exclusive action models, police patrol cars in The Netherlands, Switzerland and Malaysia and the 340 that won the European Rallycross title in 1980 - would probably not have been achieved.

VOLVO 480 RANGE

The Volvo 480 range presently comprises two models - 480 Turbo and 480 ES - and a five-engine power choice. Depending upon the market variants, the Volvo 480 ES is available with a choice of three engines. The B18F, equipped with a three-way catalytic converter and Lambda sensor control, delivers a maximum output of 70 kW at 5400 r/min and gives the car a top speed of 180 km/h. The B18ED has a catalytic converter without Lambda sensor control. Maximum power is 78 kW and top speed is likewise 180 km/h. The variant without a catalytic converter - the B18E - powers the fastest 480 ES and offers a top speed of 185 km/h with a maximum output of 80 kW.

The Volvo 480 Turbo, Volvo's range leader in the 480 line-up, is available with two engine variants. One with a three-way catalytic converter and Lambda sensor the B18FT, the other without a catalytic converter for countries where unleaded petrol is not generally available (the B18FTM). The car is not in the first place designed for extravagant road performance. The B18 Turbo engine - with its watercooled turbocharger, electronic boost control and intercooling - primarily enhances the dynamic safety of the car. The turbocharger makes it possible to respond quickly when overtaking as well as enhancing driving pleasure while still retaining the Volvo comfort, durability and reliability.

With the arrival of the Volvo 480 Turbo, Volvo introduces a car for the group of motorists who wish to express their individuality and at the same time stand out from the crowd. People who like cars with a distinctive styling, a dynamic charisma and sporty performance - all with a certain élan. Yet without making the slightest concession to the stringent criteria which determine the Volvo standard.

The new Volvo 480 Turbo has been developed for a young public. Men and women between 25 and 40, generally with a higher than average education and with career ambitions. People with an individual lifestyle who actively participate in sport and recreation in their leisure time, who are sensitive for fashion changes, are interested in culture and like to enjoy the good things in life.

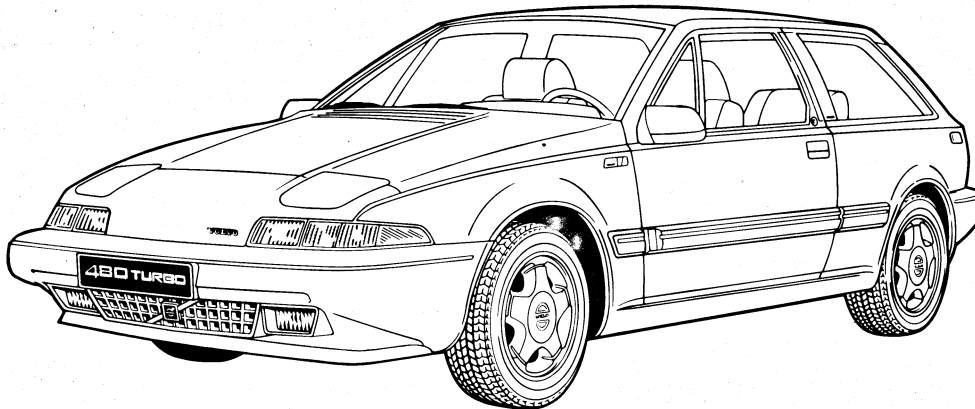

The car is characterized by the following properties:

- Modern and compact concept with front wheel drive and a sleek, low body line.
- Inviting and tastefully appointed interior with distinctly sporting overtones.
- Comfortable accommodation for four adults.
- High level of comfort and driving pleasure.
- Complete and comfortable standard equipment package.
- Well-endowed with sophisticated electronics.
- Sporty performance.
- Very respectable fuel economy.
- Only 10 hours maintenance required in the first 100,000 km, including oil changes.
- Eight years Corrosion Protection Warranty covering rust and corrosion from within.
- Built to the traditional Volvo standards of quality, safety, comfort, durability and reliability.

In brief, all the properties that appeal to the group of motorists who wish to express their individuality and at the same time stand out from the crowd.

Turbo-power à la Volvo

The design concept of the B18 Turbo is not based on outright top-end power. Instead, the emphasis has been placed on enhanced torque through the gears, particularly in the lower engine speed band. This emphasis on low-end torque and extra overtaking performance in the vital mid-range is fully in keeping with the Volvo philosophy of dynamic safety and driving pleasure. And by reason of the sophisticated technology by which this is achieved, no sacrifices whatever are made in respect of the comfortably low noise level when accelerating, nor with regard to the reliability and longevity of the engine or turbocharger unit. Equally important are the good fuel consumption figures obtained with both variants of the Volvo 480 Turbo.

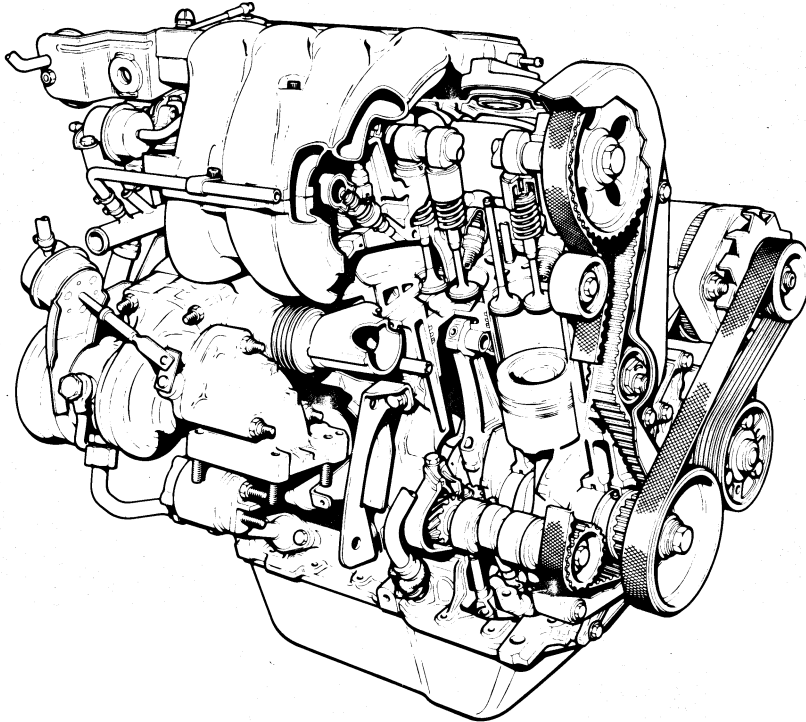

Equipment

Starting with the very full equipment of its sister model, the 480 ES, the Volvo 480 Turbo has an even more complete package. This embraces colour-matched bumpers, an extra deep front spoiler, twin fog lights and a dash-mounted turbo boost gauge, entrance lights left and right front. There are Turbo decals on the lifting tailgate and on both B-pillars. Options include air-conditioning, ABS, headlight jet-wash, metallic paint, a lifting moonroof and leather upholstery.

Technical summary

The base engine in the Volvo 480 Turbo is the 1.7-litre cylinder block introduced with the 480 ES. It is a relatively high compression Heron head unit, featuring an intercooler to optimize power output and fuel consumption, and a small diameter watercooled turbocharger with electronic boost pressure control. An oil cooler is standard while additional cooling systems are provided for fuel system components and the engine plus the turboshaft bearings to eliminate all possibility of post-driving heat soak problems.

The three-way catalytic converter variant satisfies the stringent exhaust emission requirements of US83. The end result - both in catalytic converter and non-catalytic form - is a smooth-running engine with high torque at low revs and without turbo-lag, offering fast response and enhanced comfort at the wheel.

The technology

The engine for the new Volvo 480 Turbo is a watercooled 4-cylinder unit with a cubic capacity of 1721 cc and a compression ratio of 8.1:1. It is equipped with a watercooled turbocharger with electronic boost control and intercooling. Maximum power is 88 kW/120 hp at 5400 r/min while torque peaks at a very healthy 175 Nm. Maximum torque is available from low down the engine speed band (1800 r/min) in both the catalytic converter and non-catalytic variants.

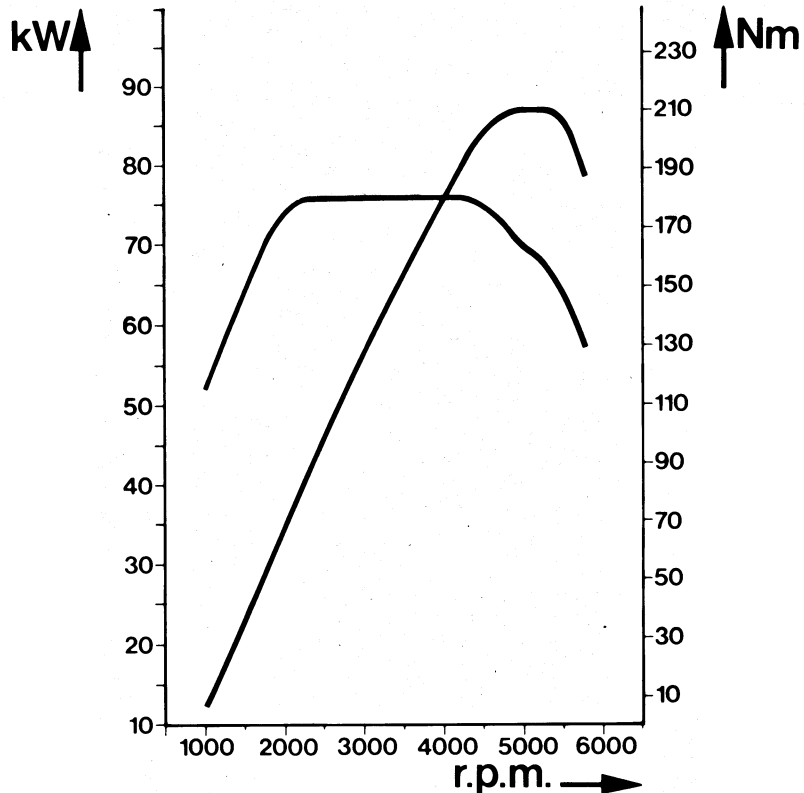

Power-and Torque curves of Volvo 480 Turbo

Watercooled turbocharger

To eliminate the risk of overheating damage to either the turbocharger or the cylinder block/cylinder head, watercooling is used for the turboshaft bearings. This cooling continues by means of a separate electric water pump, actuated by cylinder head temperature, located in the cooling circuit of the turbocharger and the cylinder head. It guarantees a flow of coolant, if required, after the engine has been switched off and even when the key is withdrawn from the ignition switch. This rapidly cools the engine and turboshaft bearings down to acceptable values and eliminates the heat soak problems that can affect other (water cooled) turbochargers and in many cases ultimately result in bearing seizure. An enhanced life is also obtained for many of the engine components, while there is no need - as with many other turbocharged engines - to let the engine run at idle for a few minutes to give the turbo time to cool down.

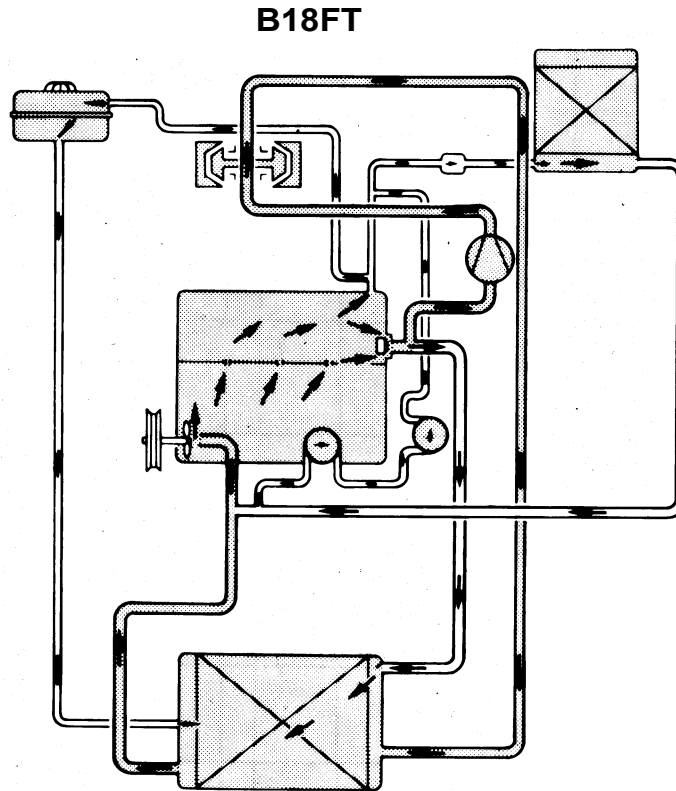

Turbo-Cooling Circuit

Electronic boost control

The B18 Turbo engine is equipped with an electronic boost pressure control unit with both a protective and an active function.

Use is made of a mechanical wastegate with a low threshold setting of 0.28 bar. Via a proportional valve, part of the boost pressure is admitted behind the wastegate. This raises the boost pressure. Thanks to the electronic control used on the 480 Turbo, a virtually flat torque curve is obtained without the uncomfortable turbo-lag phenomenon.

In its protective role, the electronic boost pressure unit limits the boost pressure to an upper design ceiling and will even cut off the fuel supply if a situation occurs which threatens to damage the turbocharger or the engine. It takes similar protective action in the event of engine overheating or persistent or severe knocking, by retarding the ignition and lowering the boost pressure.

The active boost pressure function consists in obtaining the highest possible torque at the bottom end of the engine speed band, and obtaining a virtually flat torque curve over the widest engine speed range possible. In practice, this means that maximum torque of 175 Nm is available from 1800 r/min and is sustained up to 4600 r/min.

Small diameter turbocharger

By combining this electronic turbo boost system with a small diameter (2") turbocharger, Volvo's design engineers have succeeded in eliminating the traditional turbo-lag phenomenon. In a turbocharged car, the absence of this 'delayed action' acceleration is very noticeable and contributes greatly to the comfort of the occupants and to the sense of security experienced at the wheel of the Volvo 480 Turbo.

Intercooling

The Volvo 480 Turbo is equipped with an intercooler in order to obtain the best possible ratio between fuel consumption and available power and - with a keen eye to engine longevity - to keep the combustion temperature within the design limits.

Extra cooling fan for fuel system

The B18 Turbo engine on the Volvo 480 Turbo has an extra cooling fan, actuated by a thermal switch in the cylinder head, which provides additional cooling of fuel system components which are exposed to possible heat soak. Air is drawn through the scuttle intake and blown through a special gallery located along the length of the fuel injection manifold and the injectors. In this way, vapour lock due to heat soak is prevented and effortless starting is ensured even in very hot conditions.

Extra engine features

In view of the higher operating temperatures and greater forces set up in a turbocharged engine, the B18 Turbo has several extra features compared with the base 1.7-litre block. These include:

- Sodium-filled exhaust-valves for enhanced heat dissipation.
- Additional stiffening ribs in the cylinder head.
- Additional damping volume in the inlet manifold to equalize the boost pressure.
- A single coupling between the turbocharger outlet and the exhaust pipe. This Ø 57 mm coupling absorbs both vibrations and larger displacements of these components.
- Exhaust manifold consisting of a single cast iron gallery between the cylinder head and the turbocharger intake.

Engine Management System

The Engine Management System consists of three separate units - microprocessor controlled - for the ignition, the injection and the boost pressure. These units are interactive and together ensure optimum performance and fuel consumption in all operating conditions:

- Electronic ignition mapping system
 - Electronic boost control.
 - Multipoint fuel injection (hot-wire system)
-] combined in one housing.

In illustration of their interactive operation, after a cold start and during the warming up period both the ignition timing and the quantity of injected fuel are continuously adjusted for optimum performance and driveability with minimum fuel consumption.

Knock sensor

The B18 Turbo has a built-in knock sensor to prevent possible pinking damage to the engine caused by inferior grade fuel. Each cylinder is separately regulated by this anti-knock control system

If excessive detonation occurs in one or more cylinders, the knock sensor will immediately retard the ignition. If this is not sufficient to eliminate the detonating phenomenon, the boost pressure will also be reduced until a normal situation is reached again.

Anti-lock Braking System

Down the years Volvo has consistently introduced new passive and active safety features designed to provide the best possible protection for drivers and passengers. To raise the dynamic safety level even more, an anti-lock braking system has been developed for the Volvo 480. This ABS is ideally matched to the high-tech concept of the car. Four sensors are used to monitor the speed of each wheel and provide almost instantaneous feedback to the electronic control unit. The hydraulic pressure is regulated in 3 different brake circuits (the front wheels separately plus the rear axle) for optimum braking effect.

Together with the almost perfect balance offered by the standard suspension and braking system of the Volvo 480, this Volvo developed ABS raises the active safety level on slippery surfaces to a new high. Much attention has been devoted to obtaining good feedback of the braking effort via the brake pedal, so that the driver is always aware of the driving conditions. This is complemented by the automatic self-correcting action of the front axle (kidney shaped apertures in the lower wishbone flexible bushes). Together with the ABS, this provides an incredibly stable braking behaviour in all driving conditions and for all drivers, because no special skills are required to brake safely with this anti-lock braking system.

The new ABS from Volvo has many advanced features which will not be found on most other contemporary systems. Its forefront electronics include a computerized self-diagnostic system which has details of static and dynamic failures stored in the electronic control unit's memory. This information can be read in the workshop by means of a special connector and a flash code. Furthermore every 10 seconds the electronic control unit automatically tests the electric and electronic systems of the ABS. The rear wheel speed is used as a reference for the ABS function on the front wheels. The Volvo 480 ABS also features an extrapolation facility. This enables the ABS computer to take advance action to control the wheel speed and eliminate the typical zig-zag progression in a curve.

STANDARD & OPTIONAL EQUIPMENT

480 TURBO 480 ES

Tinted glass	●	●
High impact laminated windscreen	●	●
Halogen pop-up headlights	●	●
Long-range lights	●	●
Front fog lights	●	—
Rear fog warning lamps	●	●
Reversing lights	●	●
Engine compartment illumination	●	●
Luggage compartment illumination	●	●
Impact resistant bumpers - withstand impacts up to 8 km/h without damaging the panelwork or the bumpers	●	●
Central locking	●	●
Power windows front	●	●
Electrically controlled and heated door mirrors	●	●
Anti-theft alarm	●	●
Driver's door keyhole light	●	●
Interior light with time delay	●	●
3-point inertia reel seat belts front and rear	●	●
Seat belt reminder	●	●
Electrically heated front seats (some markets)	●	●
Height adjustable driver's seat	●	●
Adjustable steering column	●	●
Adjustable lumbar support on front seats	●	●
Adjustable head restraints front	●	●
Adjustable backrest on rear seats, split rear seats for versatile load capacity	●	●
Lockable and illuminated glove box	●	●
Oddments box/armrest front and rear	●	●
Remote controlled fuel cap	●	●
Remote controlled tailgate	●	●
Electronic Information Centre	●	●
Search-find switch illumination	●	●
Headlight warning buzzer	●	●
Rheostat controlled dashboard illumination	●	●
Intermittent wipe (continuous at full throttle)	●	●
Intermittent wipe rear (continuous in reverse gear)	●	●
Automatic wash/wipe combination front and rear	●	●
Rev counter	●	●
Oil pressure gauge/voltmeter/turbo boost gauge	●	—
Colour-matched bumpers	●	—
Metallic paint	○	○
Headlight jet-wash	○	○
Air-conditioning	○	○
Leather upholstery	○	○
Moonroof	○	○
ABS	○	○

Key:

- = Standard equipment
- = Optional equipment at additional cost
- = Not available

Weights and dimensions

Dimensions in mm:

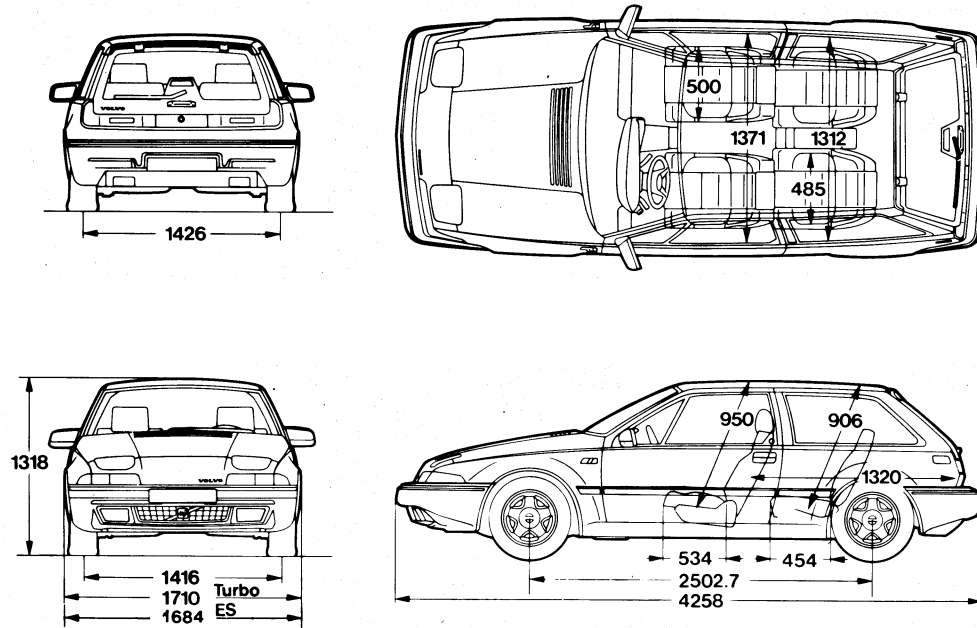

Weights:

	480 Turbo Motor B18FT, B18FTM	480 ES Motor B18E, B18ED	480 ES Motor B18F
Maximum permitted weight	1415 kg	1 390 kg	1 385 kg
Kerb weight	1040 kg	1012 kg	1016 kg
Permissible roof load	50 kg	50 kg	50 kg
Luggage compartment capacity (by SAE measurements) variable between	160-660 litres	160-660 litres	160-660 litres

VOLVO CAR B.V. CLIMBS TO PROFIT OF NLG 20 MILLION

According to the provisional annual figures which have now been released, Volvo Car B.V. earned a net profit of NLG 20 million in 1987 (1986: NLG 5.4 million). Consolidated net sales rose to NLG 2.5 billion, an increase of 14% compared with the previous year. Production and sales of cars in the 300 and 480 series reached a record level of 125,000 units (1986: 120,000).

In 1987 the product range was expanded with a right-hand drive 480 ES for the UK market and a 480 Turbo model for all European markets (except UK).

The number of employees at Volvo Car B.V. increased in 1987 to 8,000, which is 760 more than at year-end 1986. In addition, there were about 750 employees with a short-term, temporary employment contract.

Volvo Car B.V. is the sole large-scale manufacturer of passenger cars in The Netherlands. In close co-operation with the Swedish Volvo Group, Volvo Car B.V. is responsible for the development, manufacture and international marketing of the Volvo 300 series and the Volvo 480 range. Besides being mainly a car manufacturer, Volvo Car B.V. is also a producer and supplier of components for the automotive industry. The Dutch Volvo importer/distributor and four Volvo passenger car dealerships also form part of the Volvo Car B.V. organization.

Volvo Car B.V. is a limited liability company with an authorized capital of NLG 750,000,000. The issued and paid-up capital is NLG 550,955,000. Of the issued shares 30% are held by Volvo Car Corporation, the Swedish passenger car subsidiary of AB Volvo. The remaining 70% are held by Dutch interest, viz. 49% by Nationale Investeringsbank N.V., of The Hague, 18% by N.V. DSM, of Heerlen, and 3% by N.V. Industriebank L.I.O.F., of Maastricht.

The company's head office is at Steenovenweg 1, Helmond, The Netherlands.

VOLVO

Volvo Car Corporation
Public Relations & Public Affairs
S-405 08 GÖTEBORG, SWEDEN
Telephone 031-59 00 00

Press Information

VOLVO CAR CORPORATION

PRESS MATERIAL

GENEVA 1988

NEW 760 WITH INDEPENDENT REAR SUSPENSION AND 1 6-VALVE 740 GLT
- NEW ITEMS IN THE 1988 MODEL RANGE

VOLVO 760 - SOPHISTICATED TECHNOLOGY, TOP-QUALITY COMFORT
AND SOFTER LINES

VOLVO TO CONCENTRATE ON PRO-ENVIRONMENTAL CARS

THE VOLVO TRAFFIC SAFETY AWARD - THE LOGICAL EXTENSION OF
VOLVO'S WORK ON TRAFFIC SAFETY

VOLVO MAINTAINS ITS POSITION ON TOUGHENING WORLD MARKET

MAJOR CUSTOMER CARE OFFENSIVE BY VOLVO

PHOTOGRAPHS

- NEW ITEMS IN THE 1988 MODEL RANGE

A wider model range with new sophisticated technology, and continued development of quality and safety-this is the 1988 model range from the Volvo Car Corporation in a nutshell. The product programme covers attractive alternatives for car buyers in the family, sports and prestige segments.

The new 760 and 740 GLT are the major new products.

Volvo presented the new 760 last autumn. It is more or less a completely new car, with over 2,000 new components. The exterior, interior and chassis have all undergone major changes.

The exterior is new from the windscreen forwards. The rounded front, the bonnet swept up towards the windscreen and the new design of the grille and headlamps give the car a completely new face. New aluminium alloy wheels and chrome trim on the body reinforce the impression of newness.

Improved Comfort with Multi-link

The major new features on the Volvo 760 are to be found underneath. The new independent rear wheel suspension, Multi-link, increases ride comfort without sacrificing the good dynamic safety properties which have always been the hallmark of the live axle.

The lower unsprung weight allows softer springing and less damping. The vehicle is kept level even when loaded, thanks to the automatic levelling.

The volume of the fuel tank has been increased to 80 litres, and ABS brakes are standard.

The estate version, however, is not equipped with Multi-link, since Volvo wishes to give continued priority to good load-carrying capacity.

New Interior

The car has also undergone major changes on the inside, with an entirely new instrument panel as the major feature. A new adjustable steering wheel, asymmetrical placing of the handbrake lever and glove compartment lock, together with new and improved controls, contribute to a more comfortable and efficient driver environment.

The steering wheel lock and key are of a new type, and the steering wheel hub is fitted with slip coupling, which makes theft even more difficult.

The newly-designed central console contains the fully automatic new microprocessor-controlled climate unit, Electronic Climate Control.

On the audio side the loudspeakers have been given new and better positioning. And the Volvo 760 can be equipped with the radio system of the future - Radio Data System.

The interior of the new 760 is characterized by new textiled panels and a number of new colours.

The Volvo 760 is manufactured only in Volvo's Kalmar Plant.

High-level equipment

The Volvo 780 has also been equipped with Multi-link and electronic climate control. A change which underlines Volvo's ambition to give the 760 and 780 an extremely high level of equipment in their standard versions.

The Volvo 240 and 740 have not been changed on the outside, with the exception of two new colours -dark blue and dark grey metallic.

All versions of the 740 Series, including the Estate, can now be equipped with non-locking brakes (ABS).

The introduction of the new 740 GLT extends the wide choice of models offered both in the 200 and in the 700 Series.

VOLVO 760 - SOPHISTICATED TECHNOLOGY, TOP-QUALITY COMFORT AND SOFTER LINES

A completely new car with a highly personal profile. The 1988 Volvo 760 is a study in sophisticated technology and top-quality comfort.

The major new features include a softening of the lines at the front of the body, individual rear wheel suspension and changes in the interior.

Volvo has placed a great deal of emphasis on increasing the level of comfort in order to meet the requirements of buyers in the prestige segment. Sunroof, electric window lifts, electrically operated rear mirrors, central locking and a fully automatic climate unit are all standard.

The new 760 also contains a development of Volvo's traditional values of quality and safety. Non-locking brakes - ABS - are, for example, standard on all models.

A New Face

The exterior is new from the windscreen forwards. The rounded front, the sweeping bonnet and the new design of the grill and headlamps give the car a completely new face.

The bonnet has been swept up towards the windscreen and the windscreen wipers are half hidden when not in use. The bonnet is now made of aluminium and is 50 per cent lighter than a corresponding bonnet of sheet metal.

The bonnet hides Volvo's modern V6 engine with electronic injection, microprocessor-controlled ignition and active knock control. The new 760 is also available with a four-cylinder 2.3 litre turbo or a six-cylinder turbo-diesel, both with intercoolers.

The auxiliary lamps have been moved up from the spoiler to the headlamps, which means that they are better protected and also that they are cleaned by the headlamp wipers. The styling of the bumper has been changed to integrate it with the front end. The bumper is partially in matching colours, while the spoiler is always dark grey.

The new aluminium alloy wheels and chrome trim on the body reinforce the impression of a new appearance.

Independent rear-wheel suspension for increased comfort

The major new technical feature is the new independent rear-wheel suspension, Mufti-link. This design solution gives increased comfort without sacrificing the safety and road-holding characteristics of the live rear axle.

Volvo's Mufti-link has upper and lower link arms on each side, forward-pointing support arms and track rods. The link arms are anchored in a rear-axle member, in which the final drive is also mounted with bushings for isolation. The rear-axle member is in its turn mounted in the body with a further four bushings for isolation. This means that the entire suspension is simple to assemble and dismantle.

The rear axle also provides protection in a rear-end collision and the new larger fuel tank (80 litres) is mounted in a well-protected position ahead of the rear axle.

The weight of the moving parts in Volvo's Multi-link is low. The final drive, the rear part of the camshaft and the inner part of the driveshaft do not join in the movement of the wheels. Parts of the weight are moved from the wheel suspension to the section which is anchored to the body. This means lower unsprung weight, which is one of the basic prerequisites of improved ride comfort, since this makes it possible to use softer springing and less damping.

Automatic levelling

The vehicle is kept level even when loaded thanks to automatic levelling. The rear wheels are always at perpendicular to the road surface even when heavily loaded. Thanks to the automatic levelling, the full capacity of the tyres is utilized, which contributes to the good road-holding properties.

Multi-link retains the good road-holding properties of the live rear axle. The geometry has been designed so that tracking variation, as in the live rear axle, is negligible.

The somewhat higher weight of the new design in combination with the larger fuel tank has increased the overall weight of the rear end by 65 kilos. This gives the new 760 considerably better accessibility and traction on winter road surfaces.

The estate version is not fitted with Multi-link since Volvo has chosen to give priority to retaining the excellent load carrying capacity of the five-door cars.

Softer lines on the instrument panel

The interior of the new 760 has also changed, with a newly designed instrument panel as the main element. The instruments are in a more rounded setting, the controls are new and improved and both the glove compartment lock and the hand brake lever are placed asymmetrically, closer to the driver.

The steering wheel is adjustable to three positions. Airbag is standard in the USA and available as an option on left-hand drive cars in Europe. There is a new type of steering wheel lock and key, and the steering wheel hub is equipped with a slip coupling in order to make theft more difficult.

The instrument panel shell is made of injection moulded plastic for reduced weight and improved isolation against noise from the engine compartment.

New climate unit

Electronic Climate Control, ECC, is standard in the new 760s. The microprocessor-controlled climate unit is fully automatic. Double sensors make temperature regulation more efficient. Wider nozzles and air channels give ECC a maximum capacity of 140 litres of air per second. The windscreen defroster has been moved closer to the windscreen in order to function more efficiently. ECC can also be operated manually if desired.

The newly-designed central console is angled towards the driver and can also be fitted with the radio system of the future - Radio Data System. The loudspeakers are also placed in new and better positions: the treble and mid-register speakers on the topside of the instrument panel are supplemented with bass speakers in the door.

Produced in Kalmar only

The interior of the new 760 matches the high standard of the car as a whole. All the panels except the door panels are covered with colour-matched textiles. High-quality plush is standard and leather is available as an option.

The Volvo 760 is manufactured only at the Volvo Kalmar plant. The plant's concentration on one product ensures that extremely high standards of quality can be maintained.

The 1988 Volvo 760 is the result of the Volvo Car Corporation's ongoing development and is steeped in Volvo's ambition to offer its customers a safe, comfortable and well-equipped quality vehicle.

VOLVO TO CONCENTRATE ON PRO-ENVIRONMENTAL CARS

The Volvo Car Corporation is to continue to concentrate on the environment during 1988.

The Company has manufactured more than one million cars with catalytic conversion - and today seven out of ten cars which roll out from the plants are fitted with catalytic convertors.

This year more painting will be carried out with waterborne metallic.

Swedish State subsidies of car purchase tax and unleaded petrol have created major demand for catalyst cars in Sweden, and today, 82 per cent of cars in the volume segment of Volvo's Swedish sales are equipped with catalytic conversion. The figure is also on the increase in Europe, in pace with increased legislative requirements on most markets.

Volvo also has a great deal of experience of the production of catalyst cars. The Company supplied the first car equipped with catalytic conversion to the USA as early as 1976 and since 1980 all Volvos exported to the USA have been equipped with the three-way catalytic convertor.

Since the 1987 model year, cars with the Lambda Sond have also been sold on the Swedish market.

From the 1989 model year all new cars sold in Sweden must be equipped with catalytic conversion. This will considerably limit the effect of car emissions on the environment. The Association of Swedish Automobile Manufacturers has calculated that emissions of carbon dioxide, hydrocarbons and nitric oxides will by the year 2000 be back at the levels of the late fifties, in spite of the fact that the car population will continue to increase.

MORE WATERBORNE METALLIC PAINTS

The Volvo Car Corporation will successively increase the painting of bodies with waterborne metallic. Today there is one colour in production silver metallic. The goal is to rebuild one line during 1989 solely for waterborne metallic in several colours.

Parts of the paintshop in Volvo's Torslanda Plant are being rebuilt for this purpose. This is a complicated and time consuming procedure.

New spray booths, new equipment for changing colours, and new rust-free paint circulation systems are being installed. The drying tunnel is being modified and several other problems must be solved.

Volvo's technicians have devoted a great deal of energy to finding a new method of rinsing the equipment when changing colours. Careful rinsing is extremely important when changing from one colour to another, and this is more difficult to solve with waterborne paints.

TESTS FOR THE BUILDING OF ANEW PAINTSHOP

The introduction of more waterborne metallic colours is one step towards the building of a completely new paint shop which is expected to be ready during 1990.

Only waterborne top coats are to be used in this new paint shop, both for metallic and for solid colours.

MAJOR INVESTMENTS

The plant is a phase in the investments which Volvo plans up to 1992 - SEK 1,500 million during a four-year period in order to adapt the production capacity to the needs of the nineties and to continued developments in the environmental field. Volvo intends during the same period to halve the discharges of solvents.

The investments include, apart from the paint shop, a number of measures aimed at improving the environment, such as undercarriage treatment with solvent-free materials and advanced purification of waste water from the plants.

THE VOLVO TRAFFIC SAFETY AWARD -THE LOGICAL EXTENSION OF VOLVO'S WORK ON TRAFFIC SAFETY

When, in 1985, Volvo decided to institute a traffic safety award worth SEK 500,000, the objective was to contribute to a better and safer traffic environment.

"We consider our responsibility for traffic safety not to be limited solely to the cars we design and build. We also feel responsibility for the environment in which the cars are used," says Roger Holtback, President and Chief Executive Officer of the Volvo Car Corporation.

The first Volvo Traffic Safety Award (VTSA) was presented in 1986. It was shared between two entries, one from the Netherlands and one from Denmark. Both entries contained concrete examples of measures to reduce the number of accidents between drivers, cyclists and pedestrians in built-up areas. The 1987 the Volvo Traffic Safety Award was also shared: between entries from traffic safety institutes in Norway and England, which received the distinction for their excellent handbooks in traffic safety measures.

WHY VTSA?

Volvo designed its first car over sixty years ago, in 1927. Even then, the first designers considered that Volvo should represent safety and reliability.

After the Second World War, the safety aspect became increasingly important in the design of new Volvos. The safety philosophy came to permeate design work from beginning to end, and became a Volvo property.

Today, Volvo works on safety in two main areas - dynamic safety and passive safety:

- Dynamic safety means that the car should give the driver no surprises in a crisis situation. It should behave no differently than expected. The ABS braking system is one example of dynamic safety.
- Passive safety entails protection of the driver and passengers in the car if an accident does happen. The seat belt is perhaps the best and most well-known example of passive safety. Volvo's own child safety seats are another example.

Volvo has its own research laboratory for crash-testing cars and for testing the strength of various components. The company also carries out studies of crashed Volvo cars in direct conjunction with accidents -a special Traffic Accident Research Team goes to the scene of all accidents involving Volvo cars.

However, accidents do not only depend on the car and the way in which it is designed. In order to reduce the number of accidents we need good roads, city environments which protect the most unprotected, and residential areas where drivers are forced to reduce speed.

"With VTSA we at Volvo want to encourage, support and give economic help to traffic researchers who work on these vital questions," says Roger Holtback.

"VTSA should also be seen as a logical extension of Volvo's on-going work on improving traffic safety," he says.

"We also consider that a free and open dialogue between traffic safety researchers and car manufacturers is essential if we are to achieve fast and efficient results. Our own work on traffic safety, moreover, feels more meaningful if we help to create a better traffic environment and if we have an active dialogue with traffic safety researchers," continues Roger Holtback.

"What Volvo can do is to help to bring together the people with the know-how in these matters, to throw light upon different traffic safety questions and to assist in spreading the knowledge to as many people as possible around the world. This is why we instituted the Volvo Traffic Safety Award," says Roger Holtback.

WHO CAN APPLY FOR THE AWARD?

The first time VTSA was arranged, the Jury received approximately thirty proposals for measures to promote traffic safety. The second year, the Jury received and considered over seventy such proposals. VTSA can, in principle, be applied for by anyone who works in the field of traffic safety research: individual researchers, groups of researchers, government agencies, institutes, non-profit making organizations. The proposals submitted to the Jury should consist of the presentation of a project or the results of a project, such as the description of measures taken in order to raise the level of traffic safety on an existing main road, street or built-up area.

THE JURY

The international VTSA Jury consists of nine members, representatives of traffic safety organizations. The Chairman of the Jury is Mr Léon Nilles, of the International Road Safety Organization in Luxembourg, and the Secretary is Professor S O Gunnarsson of the Department of Urban Transport Planning at Chalmers University of Technology in Gothenburg, Sweden.

The Jury meets several times a year to consider proposals which have been received. Volvo has one representative on the jury. It should, however, be emphasized that the Jury works independently of Volvo.

50230-TS 880131

5250 MPJ

Over 300,000 cars in Volvo's 200 and 700 Series sold

VOLVO MAINTAINS ITS POSITION ON TOUGHENING WORLD MARKET

During 1987 the world market for cars declined by approximately 3 per cent.

Volvo's total car sales reached a figure of 418,600, a decline of 1,000 or 0.2 per cent compared with 1986.

"We have every reason to be pleased with the past year," states Roger Holtback, President and Chief Executive Officer of the Volvo Car Corporation.

"During a year with a weakening world market we have, for the first time, sold more than 300,000 cars in the 200 and 700 Series, and the new Volvo 760 received an extremely good reception in general."

About 40 per cent of Volvo cars sold in the 200 and 700 Series were estates. This meant that in 1987 Volvo was, yet again, by far the largest manufacturer in western Europe in this segment.

Continued growth for the 700 Series

The 700 Series continued to grow. Sales reached approximately 185,700 (177,800), an increase of over 4 per cent. In Volvo's 200 Series, 114,400 cars were sold (120,300).

Sales of the Dutch-manufactured 300 Series and Volvo 480 reached 118,185 (121,400).

Higher market shares in North America

In the US, the total car market declined during 1987 by approximately 10 per cent to just under 10.3 million.

Volvo's market share in the US increased, however, to 1.02 per cent (0.97). A total of 105,100 Volvo cars were sold in the US (111,110), a decline of approximately 5 per cent.

The new Volvo 760 was given an extremely good reception in the US, and the 740 Turbo also advanced its position.

Sales of Volvo cars in Canada declined to about 7,400 (7,500), but here too, Volvo's market share increased.

Highest sales ever in Sweden

Total sales of Volvo cars in the Nordic area rose to approximately 99,000 (93,500).

Volvo's car sales in Sweden were the highest ever, making Sweden Volvo's largest market after the US.

72,500 Volvo cars (64,600) were registered, in a market which totalled 316,000.

This brought Volvo's market share to 23 per cent (23.9). The model most sold in Sweden in 1987 was the 740.

Western Europe

In Europe outside the Nordic area, 176,500 Volvos were delivered, a decline by 2,300 compared with 1986.

In Great Britain the positive trend for Volvo continued. Altogether, 70,900 Volvo cars were registered (69,000) in a total market which exceeded two million for the first time. Volvo's market share was 3.5 per cent (3.7).

In West Germany, the Volvo 200 and 700 Series are maintaining their position as the foremost imported make in their segments.

More than half of Volvo's sales in West Germany consisted of estate cars. Sales of the 240 increased by over 20 per cent during 1987.

Total car registrations reached just over 17,300 (17,300).

1987 was a strong year for cars in France. The total market increased by approximately 5 per cent to around 2.05 million. Volvo's market share declined to approximately 0.9 per cent (1.0). Increased sales of Volvo 700 gave partial compensation for a decline in the 300 Series.

Major expansion in South-East Asia

South-East Asia and Japan today constitute one of the most expansive areas in the world.

Volvo sold 9,500 cars in South-East Asia and Japan during 1987, an increase of 35 per cent over the previous year. Japan -where Volvo's increase exceeded that of the total market - answered for the majority of these sales. Sales have almost tripled within the space of two years, and reached over 3,300 (2,200) in 1987.

In Thailand, Volvo sales reached 1,600 double the 1986 figure.

In Malaysia and Hong Kong, Volvo is today the biggest European make of car. In Hong Kong, Volvo holds a market share of approximately 10 per cent, and sales in 1987 amounted to over 1,600, an improvement of 4 per cent on 1986.

Volvo's international tax and duty-free car sales operation, TDS (Tourist & Diplomat Sales), continued successfully, with sales amounting to 11,600 (10,900).

Production

Capacity utilization continued at a high level during 1987.

A total of 423,800 cars (414,700) were manufactured. 107,600 of these were in the 240 Series (120,800) and 191,400 (175,000) were in the 700 Series. Production of estates remained high at 111,400 (117,100).

At Volvo Car BV in the Netherlands, a total of 124,800 cars were produced. 14,800 were Volvo 480 (3,300) and 110,000 were models in the Volvo 300 Series (115,600).

880118-E M

5250 MPJ

MAJOR CUSTOMER CARE OFFENSIVE BY VOLVO

Problem-free car ownership is high on the list of the car customer's requirements. Volvo is meeting these requirements with an ambitious programme of improved customer care: The Volvo Advantage Programme.

The goal is to develop a comprehensive package to give the Volvo customer maximum security.

The Volvo Advantage Programme, which was introduced last autumn and is now in process of intensive expansion, covers every new Volvo from the 1988 model year. It will be offered to Volvo customers all over the world after adaptation to the conditions on each individual market. The key concept in the programme is Customer Care-the personal consideration for the customer and his or her car.

"The foundations have been laid. Now we are looking at the possibilities of increasing the scope of the programme. We want to offer Volvo owners a comprehensive solution instead of isolated offers. The final objective is car ownership with a high degree of security, free of unexpected problems," says Thore Lodin, Project Manager for the Volvo Advantage Programme.

The programme is being established under different names on different markets. The main content, however, is the same:

* Roadside assistance in the USA and on most European markets. In Sweden, for example, this service is covered by insurance.

Through agreements with well-known salvage and assistance companies including Europe Assistance, the following help is now available if the car

cannot continue under its own power: roadside assistance, replacement car, hotel room where necessary, help in continuing the journey, delivery of the repaired car, rapid parts service where necessary, information and advice.

This service is included with all new Volvo cars during the first three years (two in France). This applies to breakdowns and, on most markets, also in the event of accident whether in the home country or abroad. It should be pointed out that the repair itself is not included in the package -this is covered either by insurances or by the car owner.

Cash card

An international cash card, Diners Club, is being offered to customers on most European markets. This is a normal Diners Card with Volvo identification, and is available after the normal procedures. The card can be used as a normal cash card and as payment at Volvo workshops.

Extra service during service

Replacement car and pick-up/delivery when the car is being serviced is now available on most markets. Conditions and prices do, however, vary.

The goal is to offer the customer a replacement car or alternative transportation when the car is left at a Volvo workshop for service or repairs.

It must also be possible to offer the customer pick-up and delivery of the car so that he does not need to go to the workshop himself.

This service is not free of charge, but Volvo's ambition is to offer it at reasonable cost. In Belgium, for example, all workshop customers can hire a Volvo 740 for SEK 60 per day.

Customer care in print

All buyers of a Volvo 760 or 780 also receive a free copy of the Volvo Guide, a book which contains a presentation of the company, tourist information and road maps. There is also a separate list of Volvo dealers and workshops throughout Europe. 760 customers also receive a customer video presenting car assembly and the Kalmar Plant.

Another feature of Volvo's customer care is the ambition that all Volvo owners should be offered attractive car insurance conditions. This is already available on several European markets and the system is being extended.

Customer Relations

Yet another feature is that the Volvo Car Corporation and its importers out on the markets are extending their customer relations functions in order to satisfy requirements concerning information and help.

"Volvo's customers must be able to feel that we care about them and their cars. They expect a high level of quality from us and we want to live up to those expectations," says Thore Lodin.